

## QUICK START GUIDE

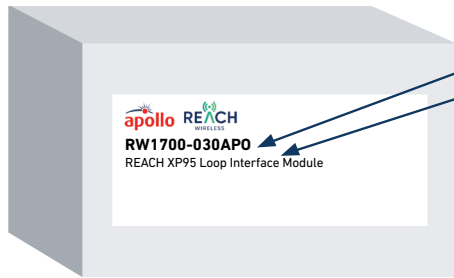

### THE BOX

Product Part Number  
Product Description

### INSIDE THE BOX

- 1 x Loop Interface Module
- 4 x Screws
- 1 x Quick start guide

### MOUNTING STEPS

The Translator Module is IP65 rated, suitable for external mounting. The back box must be installed on the wall as flat as possible to retain IP rating, to prevent distortion of the housing and the ingress of contamination and/or moisture.

Proceed as follows to complete the device installation.



### IMPORTANT TO CONSIDER

When mounting a wireless device a comprehensive radio survey should have been carried out to establish the location that provides the best coverage and optimum reach. Taking into consideration the building structure and materials, the survey identifies the wireless infrastructure required and product locations for optimum performance, identifying any factor that could prevent radio integrity.

Avoid fixing or mounting the unit close to the following:

- Equipment that utilises large electrical currents
- Large metal objects or structures
- Fluorescent lighting fittings
- Metal ceiling structures
- IT cabling.

Keep 2 meters minimum spacing between other wireless equipment in the area to avoid signal interference.



EN54 approved environmental temperature range is -10°C to +55°C

### UNBOXING

- The Translator has removable top and bottom front plastics to cover screw housings.
- The Translator is housed in an IP Rated box, with knockouts for IP rated glands.
- 4 plastic screws are provided to secure the lid.

For more information, please refer to the user manual

scan QR for full product manual



RW1700-030APO

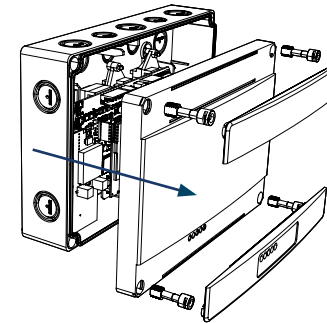

1

Remove top and bottom front plastics that cover screws, unscrew all four screws and remove the lid from the back box.

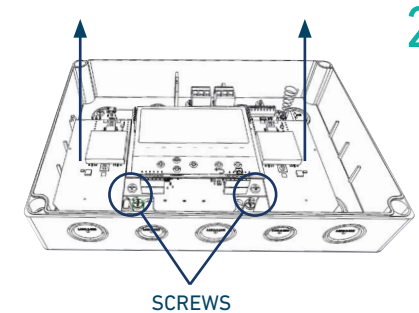

2

Remove the electronic PCB assembly from the enclosure. The PCB is held by two Philips screws below the display, it then slides up and out.

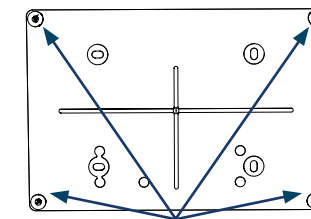

3

Using a suitable-sized drill bit (4mm) drill the pre-defined screw mounting points in the 4 corners of the backbox.

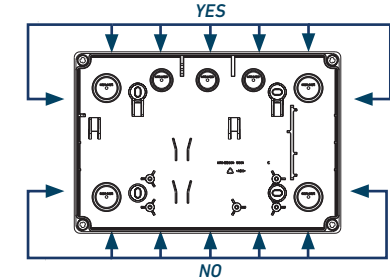

4

Prepare apertures (20mm knockouts) required for cable access and fit appropriate rated glands.

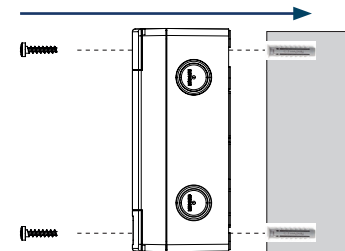

5

Screw the back box to the wall using all fixing holes and appropriate-sized roundhead screws (do not use countersunk screws).

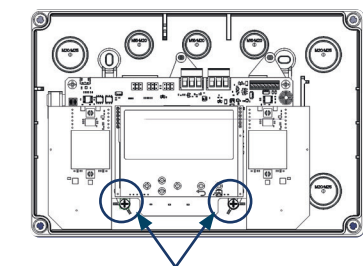

6

Insert cable, tighten glands and refit PCB and securing screws.

7

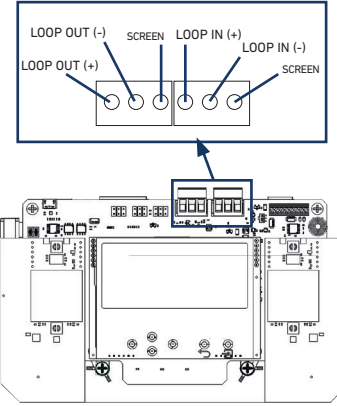

The Loop connector on the top of the translator board should be wired to the Panel of your choice, from the left to right the terminals are:

- Loop Out Positive wired to Loop In Positive on the Panel
- Loop Out Negative wired to Loop In Negative on the Panel
- Screen
- Loop In Positive wired to loop Out Positive on the Panel
- Loop In Negative wired to Loop Out Negative on the Panel
- Screen

8

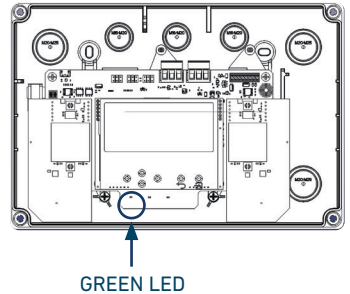

GREEN LED

- The translator will power up and the translator will be ready for commissioning phase.
- Follow the step by step instructions on the screen to complete the system setup.

9

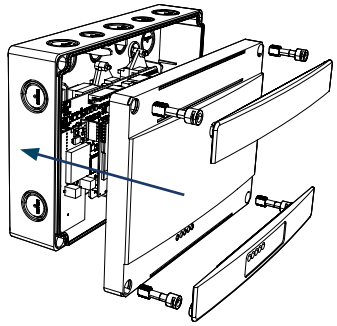

- Screw the lid to the back box using the supplied plastic screws and refit top and bottom front plastics that cover screw housings.