

# XP95



- Ionisation Smoke Detector
- Optical Smoke Detector
- Heat Detector
- Multisensor Detector
- Manual Call Point
- Isolating Base
- Sounders & Beacons



The XP95 range of intelligent fire detectors is advanced in design, improved in performance and has unique features that benefit the installer and the end user. The range includes ionisation and optical smoke detectors, heat detectors as well as a multisensor. All have an unobtrusive profile, a zero insertion force base, user friendly addressing and extended data and alarm features. A manual call point, an isolating base, sounders, beacons and other compatible products are also available.

These detectors have been carefully researched and the range has undergone rigorous testing to ensure that it meets not only European and other standards but also the demands of today's high technology environments.

This Product Guide aims to provide engineers with full information on XP95, in order to be able to design optimum solutions to fire protection problems.







Apollo Fire Detectors Limited, part of the Halma plc group of companies, operates from one site at Havant, near Portsmouth, England. All departments – Research and Development, Sales and Marketing, Manufacturing and Finance – are located there. Apollo applies the most modern production techniques and has invested in sophisticated manufacturing equipment to ensure consistent high quality of product and fast response to customer requirements. Through planned expansion Apollo has reached a leading position in the market for professional fire detectors and exports over half of its production to countries around the world.



### Contact points for enquiries and help

Technical queries	<a href="mailto:techsales@apollo-fire.co.uk">techsales@apollo-fire.co.uk</a>
Resources (literature, photos)	<a href="mailto:marketing@apollo-fire.co.uk">marketing@apollo-fire.co.uk</a>
Sales enquiries	<a href="mailto:sales@apollo-fire.co.uk">sales@apollo-fire.co.uk</a>
Phone numbers for all departments	+44 (0)23 9249 2412
Fax numbers for all departments	+44 (0)23 9249 2754
Website	<a href="http://www.apollo-fire.co.uk">www.apollo-fire.co.uk</a>

Information in this guide is given in good faith, but Apollo Fire Detectors Limited cannot be held responsible for any omissions or errors. The company reserves the right to change specifications of products at any time without prior notice.

	<b>Application of XP95 Detectors</b>	4
	<b>Addressing and Communications</b>	4
	<b>Features of the XP95 Range</b>	5
	<b>Ionisation Smoke Detector</b>	
	Operating principles	6
	Electrical description	7
	Environmental characteristics	7
	Safety note	8
	Technical data	8
	<b>Optical Smoke Detector</b>	
	Operating principles	9
	Electrical description	9
	Environmental characteristics	9
	Technical data	10
	<b>Heat Detector</b>	
	Operating principles	11
	Electrical description	11
	Environmental characteristics	11
	Technical data	12
	<b>Multisensor Detector</b>	
	Operating principles	13
	Technical data	14
	<b>Manual Call Point</b>	
	Operating principles	15
	Technical data	16
	<b>XP95 Mounting Base</b>	17
	<b>XP95 Isolating Base</b>	
	Operating principles	18
	Electrical description	18
	Technical data	18
	<b>XP95 Isolator</b>	19
	<b>XP95 Loop-Powered Beam Detector</b>	19
	<b>Intelligent Reflective Beam Detector</b>	19
	<b>MiniDisc Remote Indicator</b>	19
	<b>Loop-powered Sounders, Beacon &amp; Sounder Beacons</b>	19
	<b>XP95 Flame Detector</b>	20
	<b>Approvals and Regulatory Compliance</b>	22
	<b>EMC</b>	22
	<b>Maintenance of Detectors</b>	23

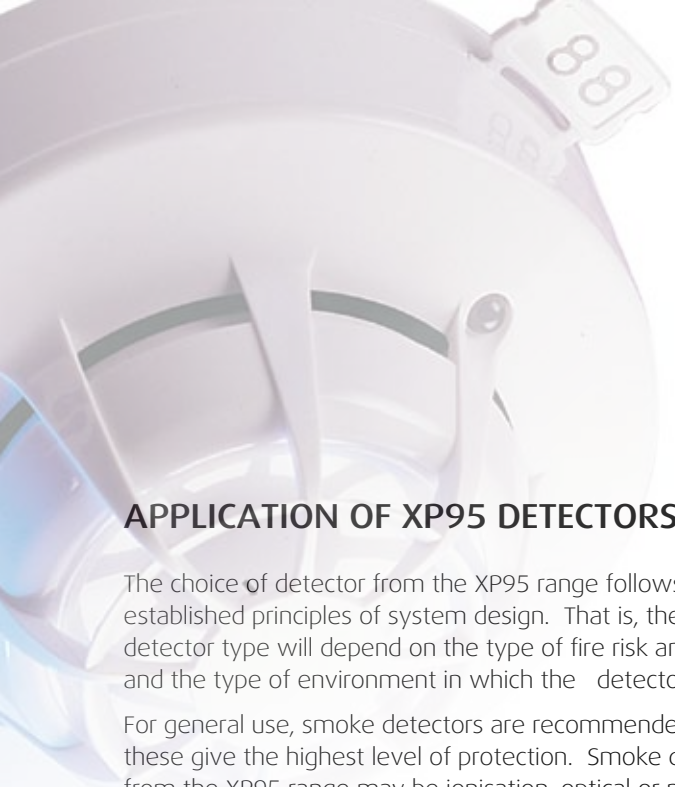

## APPLICATION OF XP95 DETECTORS

The choice of detector from the XP95 range follows the well established principles of system design. That is, the optimum detector type will depend on the type of fire risk and fire load, and the type of environment in which the detector is sited.

For general use, smoke detectors are recommended since these give the highest level of protection. Smoke detectors from the XP95 range may be ionisation, optical or multisensor types. It is generally accepted that ionisation types have a high sensitivity to flaming fires whereas optical detectors have high sensitivity to smouldering fires. As a result of this, ionisation types are widely used for property protection, and optical types for life protection. These general principles still apply to XP95 detectors although the availability of a multisensor in the range offers more choice to the system designer.

The multisensor is basically an optical smoke detector and will therefore respond well to the smoke from smouldering fires. The detector also senses air temperature. This temperature sensitivity allows the multisensor to give a response to fast burning (flaming) fires, which is similar to that of an ionisation detector. The multisensor can therefore be used as an alternative to an ionisation detector - particularly since restrictions on the transportation of ionisation detectors have been introduced.

Where the environment is smoky or dirty under normal conditions, a heat detector may be more appropriate. It must be recognised, however, that any heat detector will respond only when the fire is well established and generating a high heat output.

Unless otherwise specified, devices described in this guide are suitable for indoor use only.

## ADDRESSING AND COMMUNICATIONS

Each XP95 device responds to interrogation and command from central control equipment. It communicates to the panel information on status, command bits, type, location, and other information that allows an alarm to be raised even when the device is not itself being interrogated. Message error checking is also provided. The devices are compatible with Series 90, Discovery® and XPlorer systems and control equipment to aid maintenance, extension and upgrade of existing systems.

A unique, patented XPERT card provides simple, user friendly and accurate identification of detector location whereby a coded card, inserted in the base, is read by any detector once it is plugged in. All the electronic components are in the detector but the location information is held in the base. The address card simplifies and speeds up installation and commissioning. Addressing errors during maintenance and service are eliminated.

The XP95 manual call point continues to use DIL switch addressing, but its interrupt feature also provides automatic reporting of its location in the interrupt mode.

The XP95 detectors provide an alarm facility that automatically puts an alarm flag on the data stream and reports its address when the pre-set EN54 thresholds are exceeded. The devices provide great flexibility in system design with the control equipment determining the characteristics of the system. A large and growing range of compatible control equipment is available from many sources - details are included in Apollo publication PP1010, which is available on request.

	Ionisation	Optical	Multisensor	Heat
Overheating/thermal combustion	Poor	Very Good	Very Good	Very Poor
Smouldering/glowing combustion	Moderate/Good	Good	Good	Very Poor
Flaming combustion	Very Good	Good	Good	Poor
Flaming with high heat output	Very Good	Good	Very Good	Moderate/Good
Flaming - clean burning	Poor	Very Poor	Moderate/Good	Moderate/Good

**Table 1** Response characteristics of smoke and heat detectors.

## PROTOCOL FEATURES

### Control Unit Interrogation and Command:

3 bits of command instruction and the 7- bit address are issued by the control equipment following an initiating pulse.

### Interrupt Warning:

Notification that an XP95 manual call point or XP95 Mini Switch Monitor (interrupt) has been operated.

### Analogue Value Report:

Status continually reported.

### Input Bits Reporting:

Field devices advise control equipment of actions they have taken.

### Automatic Type Identification:

The device being interrogated replies with a 5 bit type code, allowing up to 32 device types.

### Address Confirmation:

The 7- bit address (up to 126 devices per loop) of the detector responding is confirmed back to the control unit.

### XP95 Device Flag:

Tells the control equipment that more information is available.

### Alarm Flag:

For accelerated alarm reporting.

### Parity Error Check:

For received message accuracy.

### Interrupt or Alarm Address:

Provides fast location of a device in alarm state.

### Remote Alarm Test:

All detectors may be tested by setting the relevant command bit in the protocol. The detectors should return an analogue value greater than 64. Note: This is not a substitute for a smoke test.

## ENGINEERING FEATURES

### High Level Integration:

ASICs and microcontroller technology for lower component count.

### Zero Insertion Force Base:

For easier installation and maintenance.

### Ease of Maintenance:

Snap lock chambers for easy cleaning.

### Surface Mounted Components:

For long life and high reliability

### Latest Data Reported:

As well as free running data update, device will update data when the preceding device is being interrogated.

### XPERT Card Addressing:

For fast reliable installation and service.

### Unobtrusive Design:

For elegant designs in modern buildings.

# XP95 IONISATION SMOKE DETECTOR



XP95 Ionisation Smoke Detector ▲ Part Number 55000-500/520/560

page  
6

## OPERATING PRINCIPLES

The XP95 ionisation smoke detector has a moulded self-extinguishing white polycarbonate case with wind resistant smoke inlets. Stainless steel wiper contacts connect the detector to the terminals in the mounting base. Inside the detector case is a printed circuit board that has the ionisation chamber mounted on one side and the address capture, signal processing and communications electronics on the other.

The ionisation chamber system is an inner reference chamber contained inside an outer smoke chamber (Fig 1). The outer smoke chamber has smoke inlet apertures that are fitted with an insect resistant mesh.

The radioactive source holder and the outer smoke chamber are the positive and negative electrodes respectively. An Americium 241 radioactive source mounted within the inner reference chamber irradiates the air in both chambers to produce positive and negative ions. On applying a voltage across these electrodes an electric field is formed as

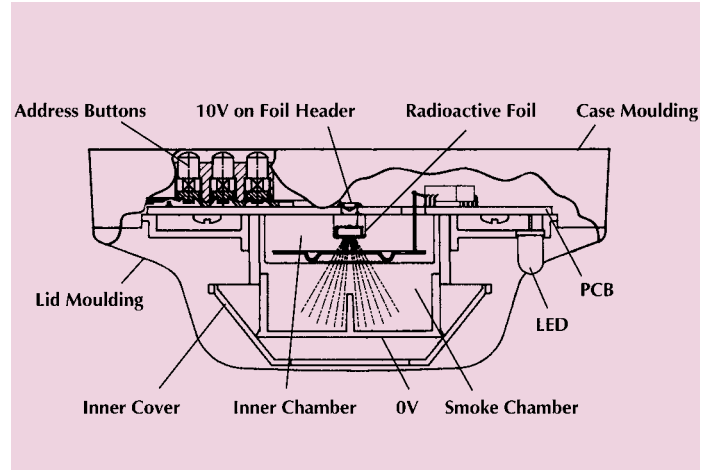

Fig.1 Sectional view - XP95 Ionisation Smoke Detector

shown in Fig 2. The ions are attracted to the electrode of the opposite sign, some ions collide and recombine, but the net result is that a small electric current flows between the electrodes. At the junction between the reference and smoke chambers is the sensing electrode that is used to convert variations in the chamber currents into a voltage.

When smoke particles enter the ionisation chamber, ions become attached to them with the result that the current

flowing through the ionisation chamber decreases. This effect is greater in the smoke chamber than in the reference chamber and the imbalance causes the sensing electrode to go more positive.

The voltage on the sensing electrode is monitored by the sensor electronics and is processed to produce a signal that is translated by the A/D converter in the communications ASIC ready for transmission when the device is interrogated.

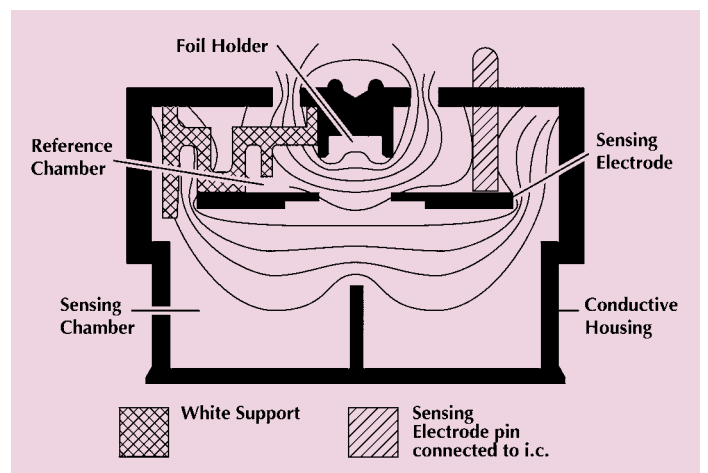

Fig.2 Diagram showing lines of equipotential for the XP95 Ionisation Smoke Monitor

## ELECTRICAL DESCRIPTION

The detector is designed to be connected to a two wire loop circuit carrying both data and a 17V to 28V dc supply. The detector is connected to the incoming and outgoing supply via terminals L1 and L2 in the mounting base. A remote LED indicator requiring not more than 4mA at 5V may be connected between +R and -R terminals. An earth connection terminal is also provided, although this is not required for the functioning of the detector.

When the device is energised the ASICs regulate the flow of power and control the data processing. The ionisation chambers are energised and the ultra low leakage sensor ASIC provides a conditioned analogue signal to the analogue to digital (A/D) converter within the communications and processing ASIC. When smoke enters the ionisation chambers through the integral gauze, the voltage at the sensing electrode increases to produce an analogue signal. An A/D conversion of the signal from the ionisation chambers is carried out once per second or when either the detector or preceding address is being interrogated. Whenever the device is interrogated this data is sent to the control equipment. EN54 threshold alarm levels are calibrated within the processing ASIC. If the device is not addressed within one second of its last polling and the analogue value is greater than 55 the alarm

flag is initiated and the device address is added to the data stream every 32 polling cycles from its last polling for the duration of the alarm level condition, except when the alarming device is being interrogated. This can provide a location identified alarm from any device on the loop in approximately two seconds.

The detector is calibrated to give an analogue value of  $25 \pm 7$  counts in clean air. This value increases with smoke density. A count of 55 corresponds to the EN54 alarm sensitivity level. See Fig 3. Counts of 8 or less indicate fault conditions. Count levels between 45 counts and 55 counts can be used to provide an early warning of fire.

## ENVIRONMENTAL CHARACTERISTICS

XP95 ionisation smoke detectors are designed to operate in a wide variety of environments (See Figs 4 to 6). There are only small effects from temperature, humidity, atmospheric pressure and wind. Detectors are well protected against electromagnetic interference over a wide frequency range.

The XP95 ionisation detector, like all ionisation detectors, has some sensitivity to air movement (wind). The extent to which the analogue value will change depends on the wind speed and on the orientation of the detector relative to the wind direction. Relatively small changes in wind direction can cause significant changes in analogue value.

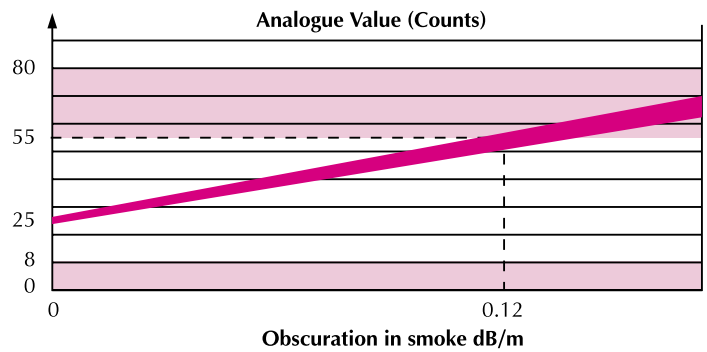

Fig.3 Typical response characteristics - XP95 Ionisation Detector

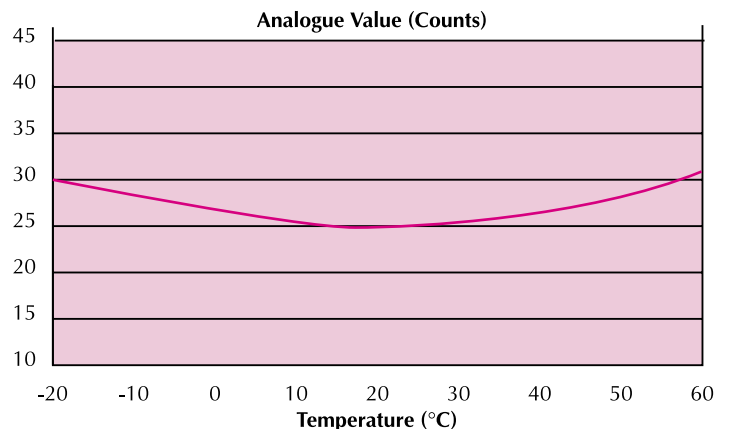

Fig.4 Typical temperature response - XP95 Ionisation Detector

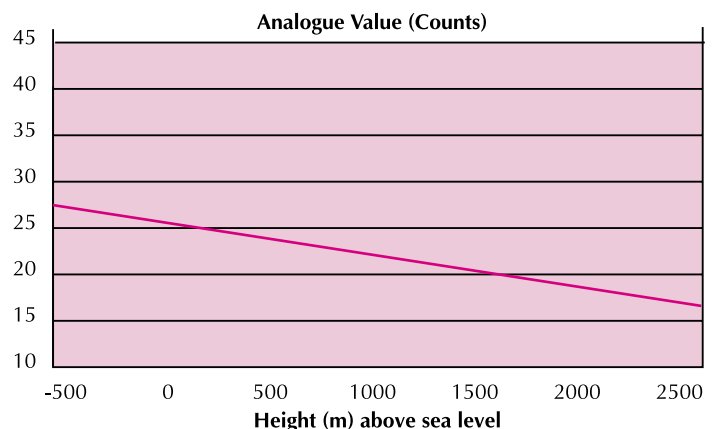

Fig.5 Typical pressure response - XP95 Ionisation Detector

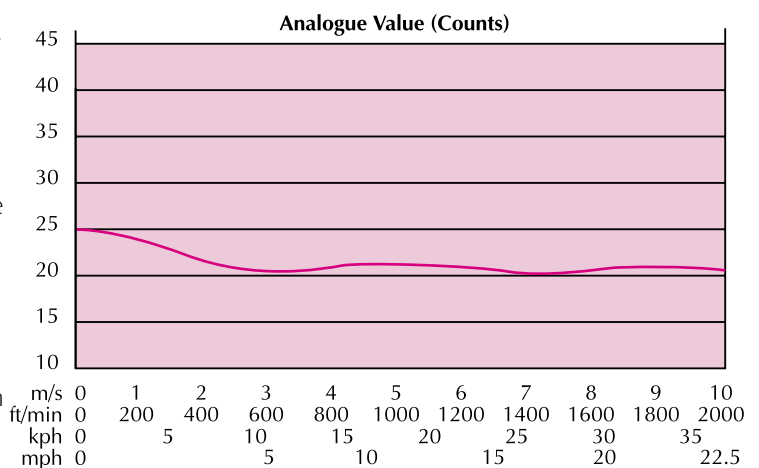

Fig.6 Typical wind speed response - XP95 Ionisation Smoke Detector

## TECHNICAL DATA

### XP95 Ionisation

Detector Part No 55000-500/520/560

Base Part No 45681-210

Specifications are typical and given at 23°C and 50% relative humidity unless otherwise stated.

### Detector Type:

Point type smoke detector for fire detection and fire alarm systems for buildings

### Detection Principle:

Ionisation Chamber

### Chamber Configuration:

Twin compensating chambers using one single sided ionising radiation source

### Radioactive Isotope:

Americium 241

### Activity:

33.3kBq, 0.9µCi

### Sampling Frequency:

Continuous

### Sensitivity:

Nominal threshold  $\gamma$  value of 0.7 to EN54-7:2000

### Supply Wiring:

Two wire supply, polarity insensitive

### Terminal Functions:

L1&L2 supply in and out connections (polarity insensitive)

+R remote indicator positive connection (internal 2.2k $\Omega$  resistance to supply +ve)

-R remote indicator negative connection (internal 2.2k $\Omega$  resistance to supply - ve)

### Supply Voltage:

17 to 28 Volts dc

### Modulation Voltage at Detector:

5 to 9 Volts peak to peak

### Quiescent Current:

280µA average, 500µA peak

### Power-up Surge Current:

1mA

### Duration of Power-up Surge Current:

0.3 seconds

### Maximum Power-up Time:

4 seconds for communications (measured from application of power and protocol)  
10 seconds to exceed 10 counts  
15 seconds for stable clean air value

### Clean Air Analogue Value:

25±7 counts

### Alarm Level 55 Counts:

EN54  $\gamma$  value of 0.7

### Alarm Indicator:

Red light emitting diode (LED)

### Alarm LED Current:

2mA

### Remote LED Current:

4mA at 5V (measured across remote load)

### Storage Temperature:

-30°C to +80°C

### Operating Temperature:

-20°C to +70°C

### Humidity:

(No condensation or icing)  
0% to 95% relative humidity

### Wind Speed:

10m/s maximum

### Atmospheric Pressure:

Automatic compensation by dual chambers to maintain sensitivity up to a height of 2000m above sea level

### Vibration, Impact & Shock:

To EN54-7:2000

### Electro-magnetic Compatibility:

See page 21 for full details

### IP Rating:

23D

### Approvals & Regulatory Compliance:

See page 21 for full details

### Dimensions: (diameter x height)

Detector: 100mm x 42mm

Detector in Base: 100mm x 50mm

### Weights:

Detector: 105g

Detector in Base: 161g

### Materials:

Detector Housing: White polycarbonate V-0 rated to UL 94

Terminals: Nickel plated stainless steel



# technical data

For wind speeds up to 1m/s (200ft/min) the change in analogue value will not exceed 5 counts. Continuous operation in wind speeds greater than 2m/s (400ft/min) is not recommended. However, wind speeds up to 10m/s (2000ft/min) can be tolerated for short periods and will not under any conditions increase the probability of false alarms.

## SAFETY NOTE

In the United Kingdom, ionisation smoke detectors are subject to the requirements of the Radioactive Substances Act 1993 and to the Ionising Radiations Regulations 1999 made under the provisions of the Health and Safety at Work Act 1974.

The detectors, independently tested by the National Radiological Protection Board (NRPB), conform to all the requirements specified in the 'Recommendations for ionisation smoke detectors in implementation of radiation standards' published by the

Nuclear Energy Agency of the Organisation for Economic Co-operation and Development (OECD) 1977.

There is no limit to the number of ionisation smoke detectors which may be installed in any fire protection system within the UK. See Certificate of Approval No. TA1 of 1999 issued by the HSE for further details.

Storage regulations depend on local standards and the legislation, but, in the UK, the number of ionisation smoke detectors in any building or premises shall be less than 500. See Certificate of Approval No. TA3 of 1999 issued by the HSE for further details.

At the end of their recommended working life of ten years, ionisation smoke detectors should be returned to Apollo for safe disposal or disposed of in an otherwise locally approved and environmentally safe manner.

Guidance on storage can be given by Apollo Fire Detectors and full details can be requested from:

Radioactive Substances Regulation Function  
Environment Agency  
Rio House, Waterside Drive  
Aztec West, Almondsbury,  
Bristol, BS32 4UD.

Outside the UK, please contact the relevant national agency.



# XP95 OPTICAL SMOKE DETECTOR



XP95 Optical Smoke Detector ▲ Part Number 55000-600/620/660

## OPERATING PRINCIPLES

The XP95 optical detector uses the same outer case as the ionisation smoke detector and is distinguished by the indicator LED which is clear in standby and red in alarm. Within the case is a printed circuit board which on one side has the light proof labyrinth chamber with integral gauze surrounding the optical measuring system and on the other the address capture, signal processing and communications electronics.

An infrared light emitting diode within its collimator is arranged at an obtuse angle to the photo-diode. The photo-diode has an integral daylight-blocking filter.

The IR LED emits a burst of collimated light every second.

In clear air the photo-diode receives no light directly from the IR LED because of the angular arrangement and the dual mask. When smoke enters the chamber it scatters photons from the emitter IR LED onto the photo-diode in an amount related to the smoke characteristics and density. The photo-diode signal is processed by the optical ASIC and passed to the A/D converter on the communications ASIC ready for transmission when the device is interrogated.

## ELECTRICAL DESCRIPTION

The detector is designed to be connected to a two wire loop circuit carrying both data and a 17V to 28V dc supply. The detector is connected to the

incoming and outgoing supply via terminals L1 and L2 in the mounting base. A remote LED indicator requiring not more than 4mA at 5V may be connected between the +R and -R terminals. An earth connection terminal is also provided.

When the device is energised the ASICs regulate the flow of power and control the data processing. The optical ASIC is controlled by the communications ASIC and pulses the IR LED. The signal from the photo-diode is processed by the optical ASIC and transferred to the communications ASIC where it is then stored. When smoke enters the chamber the photo-diode signal increases. The information to the A/D converter is updated once per second or when either the monitor or the preceding address is interrogated. Whenever the device is interrogated this data is sent to the control equipment. EN54 threshold alarm levels are calibrated within the processing ASIC. If the device is not addressed within one second of its last polling and the analogue value is greater than the EN54 alarm level the

alarm flag is initiated and the device address is added to the data stream every 32 polling cycles from its last polling for the duration of the alarm level condition, except when the alarming device is being interrogated. This can provide a location identified alarm from any device on the loop in approximately two seconds.

The detector is calibrated to give an analogue value of  $25 \pm 7$  counts in clean air. This value increases with smoke density. A count of 55 corresponds to the EN54 alarm sensitivity level. See Fig. 9.

## ENVIRONMENTAL CHARACTERISTICS

The XP95 optical smoke detector is unaffected by wind or atmospheric pressure and operates over the temperature range  $-20^{\circ}\text{C}$  to  $+60^{\circ}\text{C}$ . See Fig. 10.

page  
9

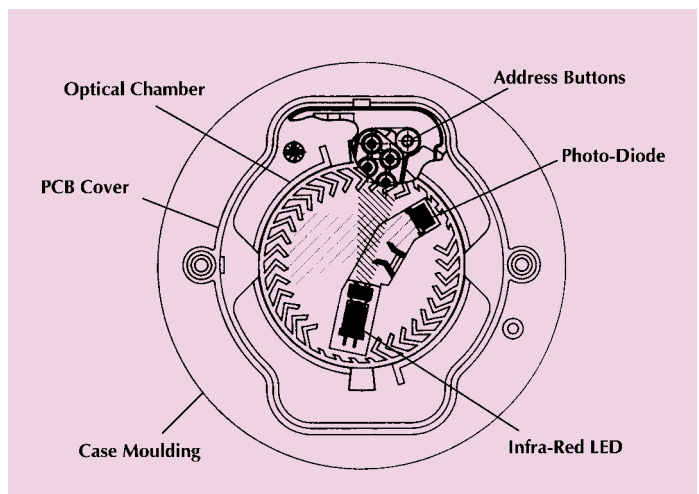

Fig.7 Top section - XP95 Optical Smoke Detector

## TECHNICAL DATA

**XP95 Optical Smoke Detector**  
**Detector Part No 55000-600/**  
**620/660**  
**Base Part No 45681-210**

Specifications are typical and given at 23°C and 50% relative humidity unless otherwise stated.

**Detector Type:**

Point type smoke detector for fire detection and fire alarm systems for buildings

**Detection Principles:**

Photo-electric detection of light scattered in a forward direction by smoke particles

**Chamber Configuration:**

Horizontal optical bench housing an infrared emitter and sensor arranged radially to detect scattered light

**Sensor:**

Silicon PIN photo-diode

**Emitter:**

GaAs Infra-red light emitting diode

**Sampling Frequency:**

1 second

**Sensitivity:**

Nominal response threshold value of 0.12 dB/m when measured in accordance with EN54-7:2000

**Supply Wiring:**

Two wire supply, polarity insensitive

**Terminal Functions:**

- L1&L2 supply in and out connections (polarity insensitive)
- +R remote indicator positive connection (internal 2.2kΩ resistance to supply +ve)
- R remote indicator negative connection (internal 2.2kΩ resistance to supply - ve)

**Supply Voltage:**

17 to 28 Volts dc

**Quiescent Current:**

340µA average, 600µA peak

**Power-up Surge Current:**

1mA

**Duration of Power-up Surge Current:**

0.3 seconds

**Maximum Power-up Time:**

4 seconds for communications (measured from application of power and protocol)  
 10 seconds to exceed 10 counts  
 35 seconds for stable clean air value

**Alarm Level Analogue Value:**

55

**Clean Air Analogue Value:**

25±7 counts

**Alarm Indicator:**

Clear light emitting diode (LED) emitting red light

**Alarm LED Current:**

4mA

**Remote LED Current:**

4mA at 5V (measured across remote load)

**Storage Temperature:**

-30°C to +80°C

**Operating Temperature:**

-20°C to +60°C

**Humidity:**

(No condensation or icing)  
 0% to 95% relative humidity

**Wind Speed:**

Unaffected by wind

**Atmospheric Pressure:**

Unaffected

**Electro-magnetic Compatibility:**

See page 21 for full details

**IP Rating:**

23D

**Approvals & Regulatory Compliance:**

See page 21 for full details

**Vibration, Impact & Shock:**

To EN54-7:2000

**Dimensions:** (diameter x height)

Detector: 100mm x 42mm  
 Detector in Base: 100mm x 50mm

**Weights:**

Detector: 105g  
 Detector in Base: 157g

**Materials:**

Detector Housing: White polycarbonate V-0 rated to UL 94  
 Terminals: Nickel plated stainless steel



technical data

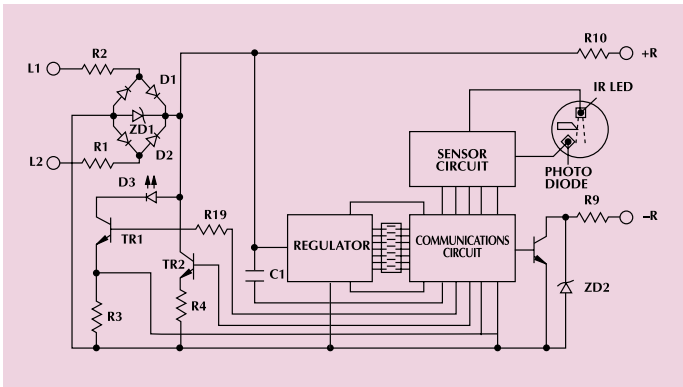

Fig.8 Schematic diagram - XP95 Optical Smoke Detector

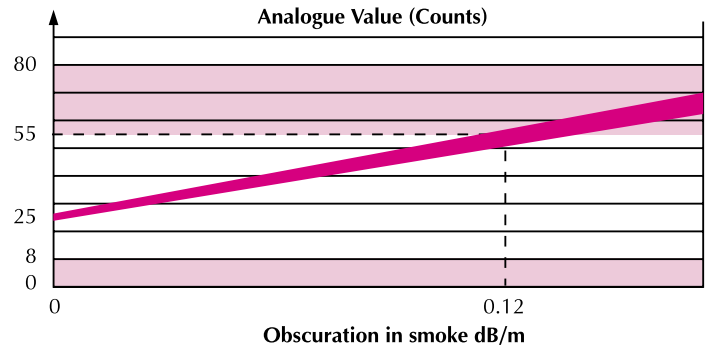

Fig.9 Typical Response Characteristic - XP95 Optical Smoke Detector

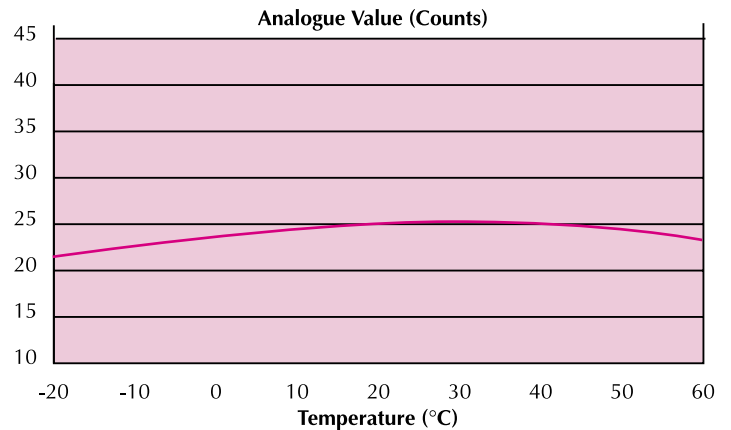

Fig.10 Typical Temperature Response - XP95 Optical Smoke Detector

# XP95 HEAT DETECTOR



XP95 Heat Detector

▲ Part Number 55000-400/420

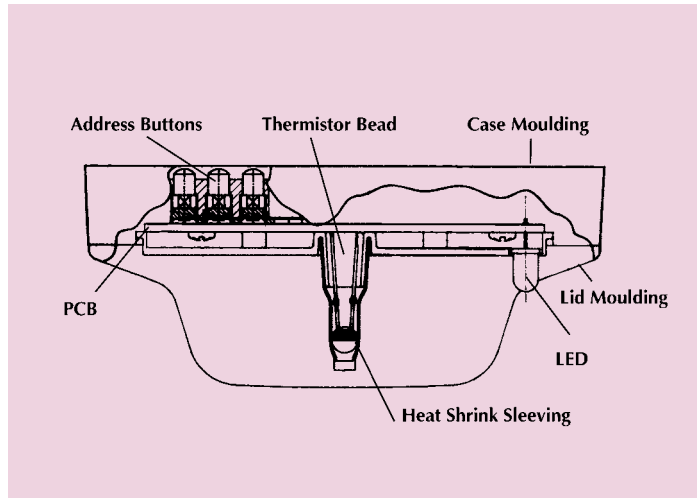

Fig.12 XP95 Heat Detector

## OPERATING PRINCIPLES

The XP95 heat detectors have a common profile with ionisation and optical smoke detectors but have a low air flow resistance case made of self-extinguishing white polycarbonate. The devices monitor heat by using a single thermistor network which provides a voltage output proportional to the external air temperature.

The standard heat detectors, 55000-400 and 55000-420, respond to increasing air temperature in such a way that they are classified as an A2S device. See Fig. 13. Both devices will give 55 counts at 55°C.

A high temperature CS heat detector, 55000-401, which can be installed in a typical ambient temperature of 55°C is available. See Fig. 14. This device will give 55 counts at 90°C.

## ELECTRICAL DESCRIPTION

The detectors are designed to be connected to a two wire loop circuit carrying both data and a 17V to 28V dc supply. The detectors are connected to the incoming and outgoing supply via terminals L1 and L2 in the mounting base. A remote LED indicator requiring not more than 4mA at 5V may be connected between +R and -R terminals. An earth connection terminal is also provided.

When a device is energised the ASIC regulates the flow of power and controls the data processing. The thermistor provides an output over normal operating ranges that is proportional to the external air temperature. This voltage output is processed in the A/D converter and stored by the communications ASIC. It is transmitted to control equipment when the device is interrogated. When a count of 55 is exceeded the alarm flag is initiated and the device address is added to the data stream every 32 polling

cycles from its last polling for the duration of the alarm level condition, except when an alarming device is being interrogated. This can provide a location identified alarm from any device on the loop in approximately two seconds.

The detector is calibrated to give an analogue value of 25±5 counts at 25°C.

page  
11

## ENVIRONMENTAL CHARACTERISTICS

XP95 Standard Heat Detectors operate over the range -20°C to +70°C, the High Temperature Heat Detectors operate over the range -20°C to +120°C. The detectors are unaffected by atmospheric pressure.

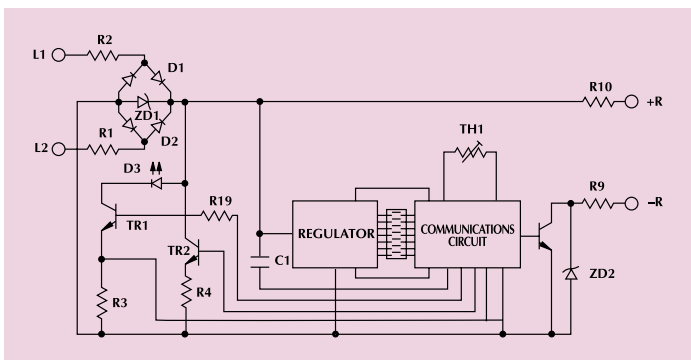

Fig.11 Schematic diagram - XP95 Heat detector

## TECHNICAL DATA

**XP95 Heat Detector (Standard)**  
**Detector Part No**  
**55000-400/420**  
**Base Part No 45681-210**

Specifications are typical and given at 23°C and 50% relative humidity unless otherwise stated.

### Detector Type:

Point type heat detector for fire detection and fire alarm systems for buildings

### Detector Principle:

Linear approximation over temperature range 25°C to 90°C

### Sensor:

Single NTC Thermistor

### Sampling Frequency:

Continuous

### Sensitivity:

25°C to 90°C: 1°C/count.  
 -20°C returns 8 counts

### Supply Wiring:

Two wire supply, polarity insensitive

### Terminal Functions:

L1&L2 supply in and out connections (polarity insensitive)  
 +R remote indicator positive connection (internal 2.2kΩ resistance to supply +ve)  
 -R remote indicator negative connection (internal 2.2kΩ resistance to supply -ve)

### Supply Voltage:

17 to 28 Volts dc

### Modulation Voltage at Detector:

5 to 9 Volts peak to peak

### Quiescent Current:

250µA average, 500µA peak

### Power-up Surge Current:

1mA

### Duration of Power-up Surge Current:

0.3 seconds

### Maximum Power-up Time:

4 seconds

### Analogue Value at 25°C

25± 5 counts

### Alarm Level 55 Counts:

55°C when measured under static conditions

### Alarm Indicator:

Red light emitting diode (LED)

### Alarm LED Current:

2mA

### Remote LED Current:

4mA at 5V (measured across remote load)

### Storage Temperature:

-30°C to +80°C

### Operating Temperature:

-20°C to +70°C

### Humidity:

(No condensation)

0% to 95% relative humidity

### Wind Speed:

Unaffected in fixed temperature use

### Atmospheric Pressure:

Unaffected

### Vibration, Impact & Shock:

To EN54-5:2000

### Electro-magnetic Compatibility:

See page 22 for full details

### IP Rating:

53

### Approvals & Regulatory Compliance:

See page 22 for full details

### Dimensions: (diameter x height)

Detector: 100mm x 42mm  
 Detector in Base: 100mm x 50mm

### Weights:

Detector: 105g  
 Detector in Base: 157g

### Materials:

Detector Housing: White polycarbonate V-0 rated to UL 94

Terminals: Nickel plated stainless steel

### XP95 High Temperature Heat Detector

**Detector Part No:**  
**55000-401**

Specifications are the same as those for the standard detector, apart from the following points:

### Detector Principles:

Linear approximation designed to give 25 counts at 25°C and 55 counts at 90°C

### Sensitivity:

25°C to 90°C: 2.17°C/count  
 -20°C returns 20 counts.



# technical data

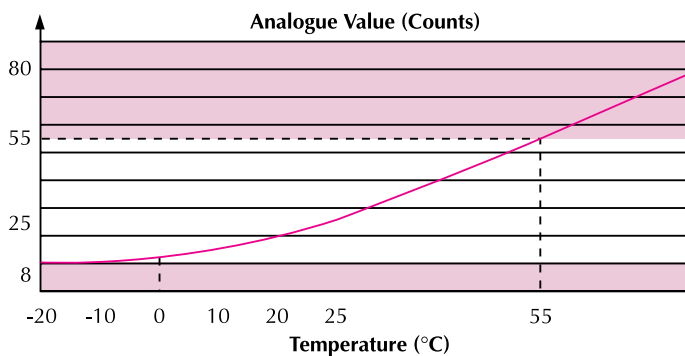

Fig. 13 Typical response characteristic - XP95 Standard heat detector

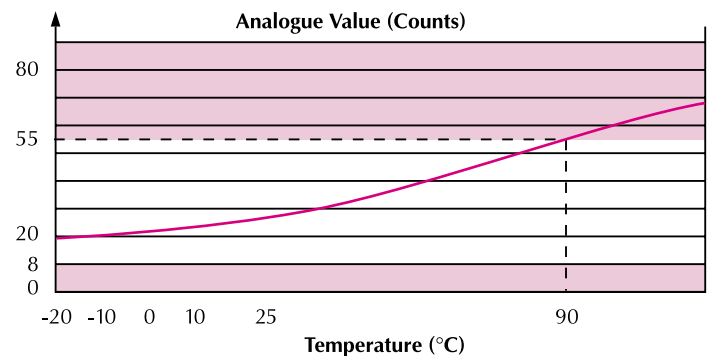

Fig. 14 Typical response characteristic - XP95 High temperature heat detector

# XP95 MULTISENSOR DETECTOR



XP95 Multisensor Detector

▲ Part Number 55000-885

## OPERATING PRINCIPLES

The XP95 multisensor detector contains an optical smoke sensor and a thermistor temperature sensor whose outputs are combined to give the final analogue value.

The multisensor construction is similar to that of the optical detector but uses a different lid and optical mouldings to accommodate the thermistor temperature sensor. The sectional view (Fig.15) shows the arrangement of the optical chamber and thermistor.

The signals from the optical smoke sensing element and the temperature sensor are independent, and represent

the smoke level and the air temperature respectively in the vicinity of the detector. The detector's microcontroller processes the two signals. The temperature signal processing extracts only rate of rise information for combination with the optical signal. The detector will not respond to a slow temperature increase - even

if the temperature reaches a high level. A large sudden change in temperature can, however, cause an alarm without the presence of smoke, if sustained for 20 seconds.

The processing algorithms in the multisensor incorporate drift compensation. The control panel must not have a drift compensation algorithm enabled.

The sensitivity of the detector is considered the optimum for most general applications since it offers good response to both smouldering and flaming fires.

Note: in situ testing of the multisensor should be carried out as for smoke detectors.

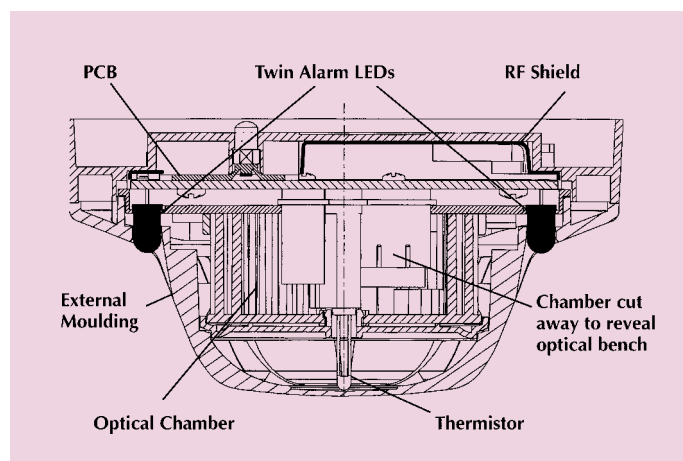

Fig.15 Sectional view - XP95 Multisensor Detector

## TECHNICAL DATA

**XP95 Multisensor Detector**  
**Detector Part No 55000-885**  
**Base Part No 45681-210**

Specifications are typical and given at 23°C and 50% relative humidity unless otherwise stated.

### Detector Type:

Point type smoke detector for fire detection and fire alarm systems for buildings

### Detector principle:

Smoke: Photoelectric detection of light scattered by smoke particles  
Heat: Temperature-sensitive resistance

### Supply wiring:

Two-wire supply, polarity insensitive

### Terminal functions:

L1&L2	supply in and out connections (polarity insensitive)
+R	remote indicator positive connection (internal 2.2kΩ resistance to positive remote indicator negative connection)

-R	remote indicator negative connection (internal 2.2kΩ resistance to negative)
----	--

### Operating voltage:

17-28V DC

### Communications protocol:

Apollo XP95 5-9V peak to peak

### Quiescent current:

500µA average 750µA peak

### Power-up surge current:

1mA

### Maximum power-up time:

10s

### Alarm LED current:

3.5mA

### Remote LED current:

4mA at 5V (measured across remote load)

### Clean air analogue value:

23 +4/-0

### Alarm level analogue value:

55

### Alarm indicator:

2 colourless Light Emitting Diodes (LEDs); illuminated red in alarm  
Optional remote LED

### Electro-magnetic compatibility:

See page 22 for full details

### Temperature range:

Max. continuous operating: +60°C

Min. continuous operating: 0°C

Min. operating (no condensation/icing): -20°C  
Storage -30°C to +80°C

### Humidity: (No condensation)

0 to 95% relative humidity

### Effect of temperature on optical detector:

Less than 15% change in sensitivity over rated range. Slow changes in ambient conditions will automatically be compensated and will not affect sensitivity

### Effect of atmospheric pressure on optical sensor:

None

### Effect of wind on optical sensor:

None

### IP rating:

23D

### Approvals & Regulatory Compliance:

See page 21 for full details

### Vibration, Impact and Shock:

To EN54-5/7

### Dimensions:

100mm diameter  
50mm height  
58mm (height in base)

### Weight:

Detector: 105g  
Detector in base: 160g

### Materials:

Housing: White polycarbonate V-0 rated to UL94  
Terminals: Nickel plated stainless steel

### Smoke element only:

**Chamber configuration:**  
Horizontal optical bench housing infra-red emitter and sensor, arranged radially to detect forward scattered light

### Sensor:

Silicon PIN photo-diode

### Emitter:

GaAs infra-red light emitting diode

### Sampling frequency:

1 per second

**CE**  
0832

technical data

**WARNING:** if the control panel incorporates a drift compensation algorithm, this should be disabled when polling the XP95 Multisensor detector.

# XP95 MANUAL CALL POINT



XP95 Manual Call Point (MCP)

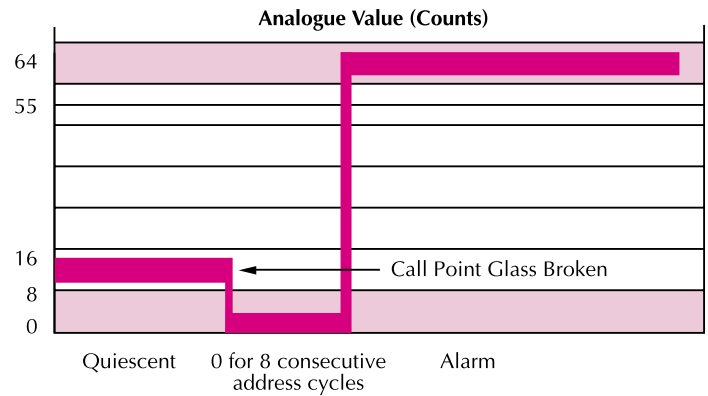

Fig.16 Typical response characteristic - XP95 Manual Call Point

## OPERATING PRINCIPLES

The new Apollo XP95 EN54-11:2001 compliant Manual Call Point (MCP) is based on the KAC conventional MCP range. It is electronically and mechanically backward compatible with previous Apollo call points based on KAC's World Series product.

The address of each call point is set at the commissioning stage by means of a seven-segment DIL switch.

A single bi-coloured alarm LED is provided on the call point. This LED is controlled, independently of the call point, by the control panel. The red LED is lit when the call point has been activated. An amber/yellow LED indicates a fault.

Call points can be remotely tested from the panel by transmission of a single bit in the communications protocol. Call points respond by providing a value of 64 which corresponds to the alarm value.

XP95 Manual Call Points are available with or without

an isolator. Each version is available with a resettable element and a backbox for surface mounting as standard. If a glass is required, it is available on request. For all part numbers please refer to Table 2.

To provide additional protection against accidental operation, a transparent hinged cover with a locking tag, part number 26729-152 is available, which can be fitted to the manual call point. *Please note that the call point does not conform to EN54-11:2001 when this lid is fitted and secured with the*

*locking tag. For weatherproof call points see Discovery guide PP2052.*

page  
15

**Important Note – the use of lubricants, cleaning solvents or petroleum based products should be avoided.**

	Colour	Deformable Element	Backbox for surface Wiring	Pattress Box	Isolated	Non-isolated
55100-905	Red	•	•			•
55100-908	Red	•	•		•	

Table 2

## TECHNICAL DATA

### XP95 Manual Call Point

Specifications are typical and given at 23°C and 50% relative humidity unless otherwise stated.

#### Call Point Type:

Deformable element

#### Call Point Principle:

Operation of a switch

#### Alarm Indicator:

Red Light Emitting Diode (LED)

#### Fault Indicator:

Amber/yellow light emitting diode (LED)

#### Supply Wiring:

Two-wire supply, polarity sensitive

#### Loop connections L1/L2:

Terminal block

#### Operating Voltage:

17V-28V dc

#### Communication Protocol:

5V-9V peak to peak

#### Quiescent Current:

100µA

#### Power-up Surge Current:

1mA

#### Maximum Power-up Time:

1 second

#### Alarm Current, LED illuminated:

4mA

#### Normal Analogue Value:

16

#### Alarm State Value:

64

#### Electro-magnetic

#### Compatibility:

See page 22 for full details

#### Temperature Range:

Max. continuous operating: +60°C

Min. continuous operating: 0°C

Min. operating: -20°C

(no condensation/icing)

Storage: -30°C to +80°C

#### Humidity:

#### (No condensation)

0 to 95% relative humidity

#### Compliance Standard:

EN54-11:2001

EN54-17:2005 (isolated version)

#### IP Rating:

24

#### Dimensions:

89mm x 93mm x 26.5mm

(manual call point)

87mm x 87mm x 32mm

(back box)

#### Weight:

151g

#### Materials:

Housing: Red Polycarbonate/ABS

Hinged cover and locking tag are also available, part

number: **26729-152**

XP95 glasses are also available, part number: **26729-154** (pack of 5)



0832

technical data



# XP95 MOUNTING BASE



XP95 Mounting Base

▲ Part Number 45681-210

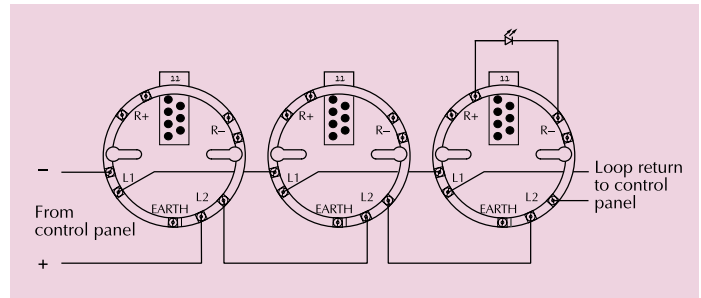

Fig.17 Schematic wiring diagram - XP95 mounting base

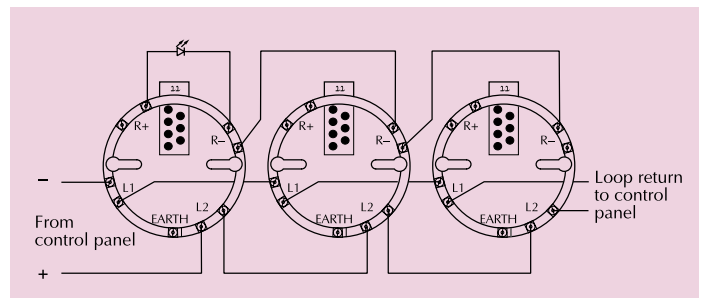

Fig.18 Schematic wiring diagram of XP95 detector circuit with a common remote LED

## XP95 Mounting Bases and XPERT cards

The XP95 smoke and heat detectors all fit the XP95 mounting base. The base is a zero insertion force base with dual finger receptacles of stainless steel into which the detector terminals slide. Cable connections of up to 2.5mm diameter are made via captive cable clamps.

There are four double terminals and one single one.

- L1- line IN and OUT, double terminal
- L2+ line IN and OUT, double terminal
- +R remote LED positive supply, double terminal
- R remote LED negative supply, double terminal

The remaining single terminal is isolated and can be used to provide continuity of an earth or shield.

Universal address cards, known as XPERT cards are supplied with all bases. Consult the coding guide to determine which pips are to be removed. Pre-printed and pre-punched address cards that save time and increase accuracy during commissioning are available in sets, part number: 45682-127.

The base has a 'one way only' fit and detectors can be locked into the base by a grub screw with the aid of a 1.5mm hexagonal driver, part number: 29600-095.

For more information on Apollo's range of bases, please refer to the Range of Bases & Mounting Accessories brochure, PP1089.

# XP95 ISOLATING BASE



XP95 Isolating Base

▲ Part Number 45681-284

## TECHNICAL DATA

### XP95 Isolating Base

**Device Part No:**  
45681-284

**Minimum supply voltage in normal operating conditions:**  
17V DC

**Maximum supply voltage:**  
28V DC plus 9V DC protocol pulses

**Isolation indicator:**  
Yellow LED, lit continuously in isolation condition

**Current consumption:**

at 18V DC	23µA
at 28V DC	43µA
at 18V DC and adjacent sector isolated	4mA

**Maximum line current:**  
Non-isolating continuous 1.0A  
Transition into isolation 3.0A

### EMC:

BS 61000-6-3  
Emission To BS EN 50081-1  
Immunity To BS EN 50130-4

**Operating temperature:**  
-20° C to +60° C

**Storage temperature:**  
-30° C to +80° C

**Relative humidity (no condensation/icing):**  
0%-95%

**Design environment:**  
Indoor use only

**Dimensions:** (diameter x height)  
100mm x 24mm  
Detector in base:  
100mm x 60mm

**Weight:**  
100g



## OPERATING PRINCIPLES

The Isolating Base senses and isolates short circuit faults on XP95 and Discovery loops and spurs.

The base is loop-powered, polarity sensitive and accepts the XPERT card to set the associated device address.

In short-circuit conditions the integral yellow LED is illuminated. The detector associated with the base remains active under short-circuit conditions. Power and signals to the affected section are restored automatically when the fault is cleared.

The Isolating Base is intended for use with equipment using the Apollo XP95 and Discovery communication protocol.

## ELECTRICAL DESCRIPTION

Under normal operating conditions, a low impedance is present between the -IN and -OUT terminals of the base, so that power and signals pass to the next base in line.

If a short-circuit or abnormally low impedance occurs, the fall in voltage is sensed and

the base isolates the negative supply in the direction of the fault. The isolated section is tested using a current pulse every five seconds. When the short-circuit is removed, the power will automatically be restored.

If it is a requirement that no device is lost in the event of a single short-circuit fault, every detector should be fitted to an isolating base.

In applications where it is not necessary to use an isolating

base for each detector, up to twenty detectors or equivalent surge current may be installed between isolating bases. See PIN sheet PP2090 for full information on loop loading between isolating bases.

Consult engineering guides or PIN sheets for quiescent current values of protected devices.

Approach Directives are also available from the Apollo website or by request.

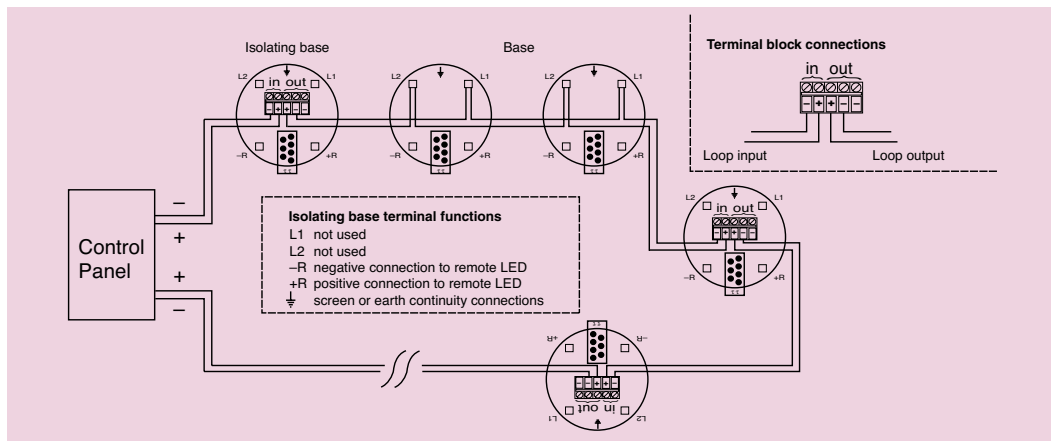

Fig.19 Schematic wiring diagram of Isolating Base

**XP95 ISOLATOR**

**Part Numbers:**

**55000-720** (isolator)  
**45681-211** (base)

‘Stand-alone’ isolators, which have their own bases, may be used instead of isolating bases. The isolators are wired to a loop between detectors or other devices.

**XP95 LOOP-POWERED BEAM DETECTOR**

**Part Number: 55000-265**

The XP95 optical beam detector has been designed to protect large open spaces such as museums, churches, warehouses and factories. It consists of three main parts: the transmitter, which projects a beam of infra-red light, the receiver, which registers the light and produces an electrical signal, and the interface, which processes the signal and generates alarm or fault signals.

The transmitter and receiver are designed to be fitted on opposite walls approximately 30cm to 60 cm below the level of the ceiling. They can protect an area up to 100m long and 15m wide, a total of 1500m<sup>2</sup>.

The interface contains the electronic circuitry needed to control the beam detector and communicate with the control panel via the XP95 loop.

The beam detector is loop-powered and needs no separate 24V supply. This not only eliminates the need for additional equipment, it also saves both cost and time in installation.

**INTELLIGENT REFLECTIVE BEAM DETECTOR**

**Part Numbers:**

**55000-268** (5-50m)  
**55000-273** (50-100m)

The intelligent reflective beam detector is a compact detector for detecting smoke in large open areas such as atria, warehouses, theatres and churches. It also has a built-in 20D negative bi-directional short circuit isolator.

The transmitter and receiver form a single unit mounted to a wall of the building. A reflector which returns the IR beam from the transmitter to the receiver is mounted on the opposite wall. In the event of smoke partially obscuring the light an imbalance between the transmitted and received light will occur. On interrogation by the control panel the detector will then transmit an alarm value.

The intelligent reflective beam detector is an addition to the Apollo range and not a replacement for the XP95 loop-powered beam detector.

The intelligent reflective beam detector is supplied in two versions: one for use at distances of 5-50m from detector to reflector and the other for distances of 50-100m.

The detector is non-latching and resets 30 seconds after an alarm event ceases and in 3 seconds after the removal of a fault.

A termination backbox, part no. 29600-241, is available. This allows easy first fixing of the cabling and terminations to the intelligent reflective beam detector. The termination backbox can be surface or flush mounted.

**MINIDISC REMOTE INDICATOR**

**Part Number: 53832-070**

A light-weight, compact indicator for use in fire protection systems. The indicator may be used in all installations incorporating Series 65, Orbis, XP95, Discovery and Intrinsically Safe detectors. It is only 20mm high and 80mm in diameter. It comprises two parts – the base, which is installed onto a wall or soffit and the lid, which is fitted to the base with a bayonet lock.

**XP95 FLAME DETECTOR**

**Part Number: 55000-280**

An infrared sensor designed to detect specific types of flame, making it immune to solar radiation and other nuisance sources of infrared. The detector is rated at IP65, uses XP95 protocol and is loop powered – eliminating the need for a separate power supply.

**BASE MOUNTED UV FLAME DETECTOR**

**Part no 55000-022**

A point flame detector mounted on a standard XP95 base used for detecting flames indoors. This detector responds to stationary as well as flickering flames.

**BASE MOUNTED TRIPLE IR FLAME DETECTOR**

**Part no 55000-024**

A point flame detector mounted on a standard XP95 base used for detecting flames indoors. This detector responds to low-frequency, flickering infra-red radiation and will detect even if the lens is contaminated by oil or dust.

**BASE MOUNTED UV/DUAL IR FLAME DETECTOR**

**Part no 55000-023**

A point flame detector mounted on a standard XP95 base used for detecting flames indoors. This detector requires both IR and UV radiation before signalling an alarm and is used where IR or UV alone might cause spurious alarms.

Full information on XP95 base mounted flame detectors is contained in PIN sheet PP2343.

**INTERFACES**

A variety of interfaces is available to suit individual applications. These include standard, wall-mounted interfaces which incorporate isolators, DIN-rail interfaces which clip to standard DIN-rails and miniature interfaces which are designed to fit into equipment such as manual call points.

Sales brochure PP2025 gives full information on the ranges of interfaces.

**INTRINSICALLY SAFE  
DETECTORS**

XP95 Intrinsically safe (IS) detectors are a development of the standard XP95 range and are for use in areas where explosive gases are or may be present. In such cases the detectors are designed not to develop sufficient energy to produce a spark and hence an explosion.

Apollo’s IS detectors are approved under the ATEX directive as well as by LPCB and the main marine certification bodies such as Lloyds.

Sales leaflet PP1094 gives full details of the IS range.

**XPANDER WIRELESS DEVICES**

The XPander range is an extension to XP95 and communicates with the loop by means of radio signals. Detectors, call points, sounders and beacons communicate wirelessly with an interface wired to the XP95 loop.

All XPander devices are transparent to the control panel so that no special panel or programming is required.

For full details of XPander please see leaflet PP2320.

**AUDIO VISUAL SIGNALLING  
DEVICES**

To complement XP95 systems and help make them DDA compliant, a choice of audio visual signalling devices and accessories is available. The ranges include base sounders and/or beacons, open area sounder-only products, beacon-only products and sounder beacon devices. The list below defines each product type:

**Base Sounders and/or  
Beacons**

These devices incorporate a base into which a detector head can be fitted, giving two, three or four functions at one point, eg detection and sounder; detection and beacon; and detection, sounder and beacon. Each combination may then also include isolation.

Alternatively, caps can be fitted to the devices so they function as sounders and/or beacons only.

**Bases**

- Ancillary Base Sounder
- Integrated Base Sounders
- Sounder Beacon Base
- Beacon Base

**Open areas**

Two ranges of sounder, beacon and sounder beacon are available for use in open areas

1. A range with a high sound output, group address facility and a synchronisation feature. These products are mounted directly onto a wall.
2. A range of products with a separate mounting base which is installed at the same time as detector bases. The base is available with or without an isolator.

**Sounders**

- Loop-powered 100dB(A) Sounder
- Intelligent Open Area Sounder (Sonos)

**Beacons**

- Loop-powered Beacon
- Intelligent Open Area Beacon (Sonos)

**Sounder Beacons**

- Multi-Tone Open-Area Sounder Beacons
- Intelligent Open-Area Sounder Beacons (Sonos)

**Accessories**

- Caps
- Beacon enclosures
- Ceiling Tile Mounting Box for sounders

Table 3 shows the functionality of each product and whether it has an integral base.

Product	Sounder	Beacon	Integral Base
Ancillary Base Sounder	✓	X	✓
Integrated Base Sounders	✓	X	✓
Sounder Beacon Bases	✓	✓	✓
Beacon Bases	X	✓	✓
Loop-Powered 100dB(A) Sounder	✓	X	X
Loop-Powered Beacon	X	✓	X
Multi-Tone Open-Area Sounder Beacon	✓	✓	X
Intelligent Open Area Sounder (Sonos)	✓	X	X
Intelligent Open Area Beacon (Sonos)	X	✓	X
Intelligent Open-Area Sounder Beacons (Sonos)	✓	✓	X

Table 3

## ALARM DEVICES FOR USE IN OPEN AREAS



### Loop-Powered 100dB(A) Sounder

#### Part Numbers:

- 55000-274 (weatherproof, red)
- 55000-275 (weatherproof, white)
- 55000-276 (slow whoop, red)
- 55000-277 (slow whoop, white)
- 55000-278 (red)
- 55000-279 (white)
- 55000-276 to 279 (indoor use only)

## BASE SOUNDERS AND/OR BEACONS



### Ancillary Base Sounder

#### Part Number: 45681-276

This is a local-area sounder with an integral base for a detector head. The sounder is switched by the detector remote output and needs no address of its own.

Sound output: 85dB(A) at 1 metre.



### Integrated Base Sounders

#### Part Numbers:

- 45681-277 (with isolator)
- 45681-278 (without isolator)
- 45681-290 (slow whoop with isolator) Dutch standard NEN2575
- 45681-291 (slow whoop without isolator) Dutch standard NEN2575
- 45681-300 (DIN tone with isolator) German standard DIN33404, Part 3

These devices incorporate a base for a detector head, feature two volume ranges and 'alert' and 'evacuate' tones. Red and white caps are available.

Sound output ranges:  
See PIN sheet PP2203



### Sounder Beacon Bases

#### Part Numbers:

- 45681-330 (with isolator)
- 45681-331 (without isolator)
- 45681-332 (slow whoop with isolator) Dutch standard NEN2575
- 45681-334 (DIN tone with isolator) German standard DIN33404, Part 3

These devices combine a local-area sounder and a flashing beacon. They incorporate a base for a detector head. Red and white caps are available.

#### Beacon Bases

#### Part Numbers:

- 45681-335
- 45681-333 (with isolator)

### Beacons



### Loop-Powered Beacon

#### Part Numbers:

- 55000-877 (red lens)
- 55000-878 (clear lens, red flash)
- 55000-879 (amber)

The beacon has been developed to alert those with hearing difficulties and for use in areas where there is a high level of background noise. The beacon is fitted to an XP95 mounting base.

The beacon is for indoor use only. However, when used with the beacon enclosure, it can be used outside. See 'Beacon Enclosure' under Accessories for more details.



**Sounder Beacons  
Multi-Tone Open-Area**

**Part Numbers:**

- 55000-293 (with isolator, red)
- 55000-294 (with isolator, white)
- 55000-298 (weatherproof, with isolator, red)
- 55000-299 (weatherproof, with isolator, white)

**Part Numbers for version without isolators:**

- 55000-291 (red)
- 55000-292 (white)
- 55000-296 (weatherproof, red)
- 55000-297 (weatherproof, white)

These devices incorporate audio and visual signalling within one unit and are designed for use in open areas. They feature selectable tones, thus minimising the number of regional variants required.

Sound output: 100dB(A), nominal



**Intelligent Open Area  
Sounder (Sonos)**

**Part Numbers:**

- 55000-001 (red)
- 55000-002 (white)



**Intelligent Open Area  
Beacon (Sonos)**

**Part Numbers:**

- 55000-009 (red with red lens)
- 55000-010 (white with clear lens)

**Intelligent Open Area  
Sounder Beacon (Sonos)**

**Part Numbers:**

- 55000-005 (Red)
- 55000-006 (White)

**ACCESSORIES**

**Caps**

Red and white caps are available for use with base sounder/beacon devices. They allow the products to function as sounders or beacons without a detector head being fitted. (excluding Ancillary Base Sounders)

See below for information on which caps are for use with which base sounder/beacon devices.

**Part numbers:**

- 29600-256 (white cap for intelligent sounders)
- 29600-257 (red cap for intelligent sounders) *All intelligent (Fulleon made) sounders and old AlarmSense sounder (45681-259)*
- 45681-292 (white cap for IBS)
- 45681-293 (red cap for IBS) *All XP95 integrated base sounders and all XP95 sounder beacon or beacon only bases; may also be used to blank off a standard XP95 base.*



**Ceiling Tile Mounting Box**

**Part Numbers:**

- 45681-309 (for use with detector bases)
- 45681-310 (for use with sounder bases)

A mounting box for use with Apollo detector and sounder bases which makes it possible to fit, wire and, if necessary, test and commission detectors before the suspended ceiling is fitted. For further details please see document no PP2229



**Beacon Enclosure**

**Part Number: 29600-318**

The beacon enclosure has a clear lid and an IP rating of 67 allowing a loop-powered beacon to be used outdoors.

## EMC

All XP95 detectors and manual call points comply with the requirements of the following EMC standards:

### **Generic Emission Standard EN 61000-6-3**

Emission standard for residential, commercial and light industrial environments.

### **Generic Emission Standard EN 61000-6-4**

Emission standard for industrial environments.

### **EN 50130-4 : Alarm Systems**

Electromagnetic compatibility - product family standard: Immunity requirements for components of fire, intruder and social alarm systems

### **EN 61000-4-2**

Electrostatic discharge

### **EN 61000-4-3**

Radiated immunity

### **EN 61000-4-4**

Fast transient bursts

### **EN 61000-4-5**

Surge immunity

### **EN 61000-4-6**

Conducted immunity

In addition, all of the XP95 detectors have been assessed to the additional VdS EMC requirements, which are shown below and have been demonstrated full compliance.

Additional VdS requirements:

30V/m with 80% amplitude sine and 100% pulse modulation depth over the frequency ranges 415 to 467MHz and 890 to 960MHz.

## APPROVALS AND REGULATORY COMPLIANCE

The XP95 range of detectors and manual call points is approved by a large number of third party certification bodies around the world. These include detector approvals to EN54:2000 with LPCB, VdS, DIBT, BOSEC and FG and to UL 268 and 521 with UL. For further information and updates on approvals held by Apollo for the XP95 range, contact the company directly or see our website, [www.apollo-fire.co.uk](http://www.apollo-fire.co.uk)

XP95 detectors comply with the requirements of a number of European New Approach Directives, such as the EMC Directive 2004/108/EC and the Construction Products Directive 89/106/EEC. Copies of EC certificates of conformity issued by various Notified Bodies under the Construction Products Directive are available from our website [www.apollo-fire.co.uk](http://www.apollo-fire.co.uk) or directly from Apollo. In addition, copies of Declarations of Conformity issued by Apollo for all applicable New Approach Directives are available upon request.

All XP95 products will comply with the marking requirements of the WEEE Directive, 2002/96/EC. For further information on disposing of applicable electrical and electronic waste, contact Apollo directly.

## MAINTENANCE OF DETECTORS

Apollo Fire Detectors has published a guide to the care, maintenance and servicing of Apollo products, PP2055, which is available on request. This guide outlines the maintenance routines recommended for optimum detector performance and the services available from Apollo's factory-based Service Department.

For more information on any of the products mentioned in this engineering guide, please refer to the following literature which is available on request.

Publication Name	Publication Number
Compatible Panel Manufacturers PIN Sheet	PP1010
Range of Bases & Mounting Accessories Brochure	PP1089
XP95 20D Isolating Base PIN Sheet	PP2039
A Guide to the Care, Maintenance and Servicing of Apollo Products	PP2055
XP95 Range of Interfaces Brochure	PP2025
XP95 Switch Monitor PIN Sheet	PP2015 (std enclosure) PP2048 (DIN-rail enclosure) PP2084 (with isolator)
Mini Switch Monitor PIN Sheet	PP2021
Mini Switch Monitor with Interrupt PIN Sheet	PP2020
Switch Monitor Plus PIN Sheet	PP2014 (std enclosure) PP2047 (DIN-rail enclosure) PP2083 (with isolator)
Zone Monitor PIN Sheet	PP2016 (std enclosure) PP2049 (DIN-rail enclosure) PP2101 (with isolator)
Sounder Control Unit PIN Sheet	PP2019 (std enclosure) PP2050 (DIN-rail enclosure) PP2094 (with isolator)
Input/Output Unit PIN Sheet	PP2017 (std enclosure) PP2045 (DIN-rail enclosure) PP2092 (with isolator)
Output Unit PIN Sheet	PP2018 (std enclosure) PP2046 (DIN-rail enclosure) PP2093 (with isolator)
XP95 Mains Switching Input/Output Unit PIN Sheet	PP2107
Dual Isolator PIN Sheet	PP2051 (DIN-rail enclosure)
XP95 Three Channel Input/Output Unit PIN Sheet	PP2121
MiniDisc Remote Indicator PIN Sheet	PP2074
XP95 Loop-Powered Beam Detector Sales Leaflet	PP2078
XP95 Flame Detector Sales Leaflet	PP2111
XP95 Flame Detector PIN Sheet	PP2110
Short Circuit Isolation in XP95 and Discovery Fire Systems	PP2090
Intelligent Reflective Beam Detector	PP2155
Ancillary Base Sounder	PP2148
Integrated Base Sounder	PP2209
Integrated Base Sounder (DIN Tone)	PP2227
Loop-powered 100dB Sounder	PP2082
Loop-powered Beacon	PP2156
Beacon Enclosure	PP2204
Sounder Beacon Base	PP2235
Multi-tone Open-area Sounder Beacon	PP2256

© Apollo Fire Detectors Ltd 1999-2008



A HALMA COMPANY



36 Brookside Road, Havant,  
Hampshire, PO9 1JR, UK.

Tel: +44 (0)23 9249 2412  
Fax: +44 (0)23 9249 2754

Email: [sales@apollo-fire.co.uk](mailto:sales@apollo-fire.co.uk)  
Web: [www.apollo-fire.co.uk](http://www.apollo-fire.co.uk)