

Troubleshooting

Before investigating faults with the Mini Switch Monitor, check all connections to the unit and the wiring of the system. Many faults are caused by simple wiring errors. Earth faults on a data loop or ancillary zone wiring may cause communication errors. Make sure that the correct value end-of-line resistor is fitted.

Fault Finding

Problem	Possible Cause
No response or missing	Incorrect address setting
Fault reported	Incorrect loop wiring
	Incorrect end-of-line fitted
Analogue value unstable	Dual address
Constant alarm	Loop fault, data corruption
	Incorrect end-of-line resistor
Incorrect type code	Incorrect wiring
	Check position of the response type setting

Note: Analogue value 3 will be reported if an earth fault is detected on the monitored circuit.

Analogue value table

Analogue Value	Status
3	Earth fault reported on monitored circuit
4	Fault
16	Normal
48	Pre-Alarm
64	Alarm



Mini Switch Monitor Installation Guide

The Mini Switch Monitor, part no 55000-760, monitors the state of one or more single-pole volt-free contacts and may be used in installations where space is limited. This unit also has a short circuit isolator as standard.

1. Connect loop wiring to terminals as shown in **Fig 1**. If the short circuit isolator is not required then both negative lines need to be wired into terminal 2.
2. Set the address using the DIL switch in accordance with the address table overleaf.
3. The eighth section of the DIL switch is used for setting the response type of the unit. Set to '1' for fast response (MCP) and set to '0' for normal (switch monitor).

Please note: When the eighth section of the DIL switch is changed, the Mini Switch Monitor will change the type code it sends to the panel. The panel will have to be programmed to accept this change.

4. Terminals five and six are used for monitoring the contacts. See **Fig 1** for wiring options.

There are two mounting options for this module:

1. Two M2.5 fixing screws at 28mm centres.
2. The unit can be attached to a standard 35mm DIN rail, see **Fig 2**. To remove device, lift the releasing clip and turn the unit anti-clockwise.

The mini switch monitor has three status LEDs:

- Red Indicates alarm condition
- Green Indicates polling
- Yellow constant, short circuit on loop wiring pulsing, fault on the monitored circuit

Wiring options for the Mini Switch Monitor

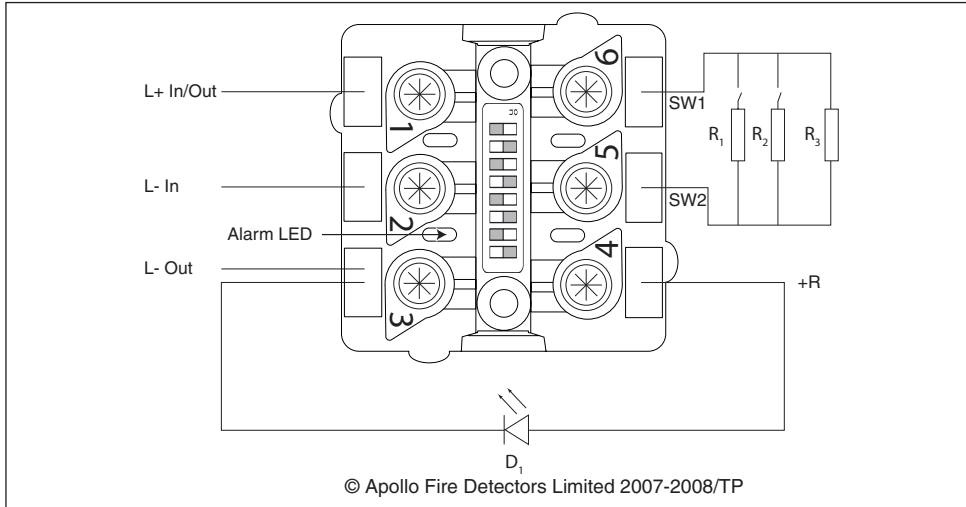

Fig 1 – Connections to the Terminals.

Key

- R₁ Alarm 1KΩ
- R₂ Pre-Alarm 10KΩ
- R₃ End of Line 20KΩ
- D₁ Optional Remote LED Part no. 53832-070 (Supplied separately) Max 3m

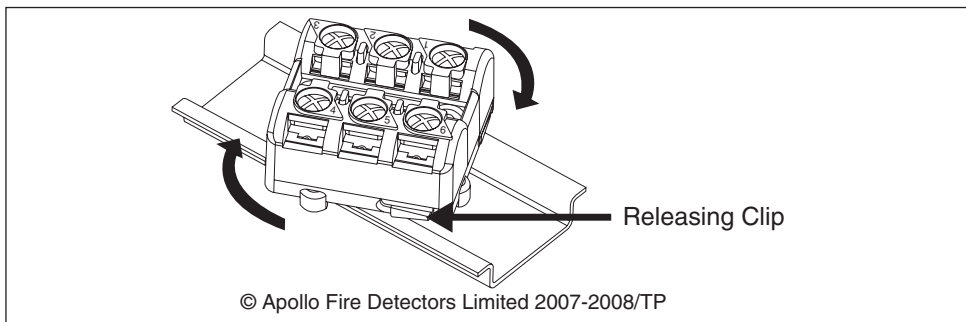
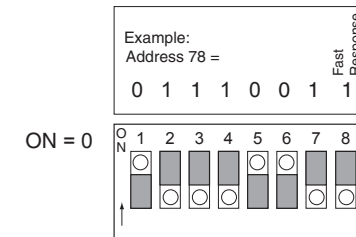

Fig 2 – Mini Switch Monitor on a DIN Rail.

Address Setting

The address of the Mini Switch Monitor is set using the first seven segments of the DIL switch. Each segment of the switch must be set to "0" or "1", using a small screwdriver or similar tool. A complete list of address settings is shown below.

addr	DIL switch setting 1234567	addr	DIL switch setting 1234567	addr	DIL switch setting 1234567	addr	DIL switch setting 1234567	addr	DIL switch setting 1234567
1	1000000	11	1101000	21	1010100	31	1111100	41	1001010
2	0100000	12	0011000	22	0110100	32	0000010	42	0101010
3	1100000	13	1011000	23	1110100	33	1000010	43	1101010
4	0010000	14	0111000	24	0001100	34	0100010	44	0011010
5	1010000	15	1111000	25	1001100	35	1100010	45	1011010
6	0110000	16	0000100	26	0101100	36	0010010	46	0111010
7	1110000	17	1000100	27	1101100	37	1010010	47	1111010
8	0001000	18	0100100	28	0011100	38	0110010	48	0000110
9	1001000	19	1100100	29	1011100	39	1110010	49	1000110
10	0101000	20	0010100	30	0111100	40	0001010	50	0100110
51	1100110	61	1011110	71	1110001	81	1000101	91	1101101
52	0010110	62	0111110	72	0001001	82	0100101	92	0011101
53	1010110	63	1111110	73	1001001	83	1100101	93	1011101
54	0110110	64	0000001	74	0101001	84	0010101	94	0111101
55	1110110	65	1000001	75	1101001	85	1010101	95	1111101
56	0001110	66	0100001	76	0011001	86	0110101	96	0000011
57	1001110	67	1100001	77	1011001	87	1110101	97	1000011
58	0101110	68	0010001	78	0111001	88	0001101	98	0100011
59	1101110	69	1010001	79	1111001	89	1001101	99	1100011
60	0011110	70	0110001	80	0000101	90	0101101	100	0010011
101	1010011	106	0101011	111	1111011	116	0010111	121	1001111
102	0110011	107	1101011	112	0000111	117	1010111	122	0101111
103	1110011	108	0011011	113	1000111	118	0110111	123	1101111
104	0001011	109	1011011	114	0100111	119	1110111	124	0011111
105	1001011	110	0111011	115	1100111	120	0001111	125	1011111
								126	0111111



© Apollo Fire Detectors Limited 2006-8/DJO/TP

Technical Data

Operating voltage 17-28 VDC
Protocol 5-9V

Current Consumption at 24V

Quiescent current 200µA
LED Operated Alarm 3.4mA + Quiescent
Remote and LED alarm 6.2mA + Quiescent
Switch fault LED +2.8mA

(Pulsing 0.5s on, 0.5s off)

For further information on isolators (20i) please refer to PIN Sheet PP2090, available on request.