



Internet Module Installation Manual



Description

The IP150+ Internet Module provides access to Paradox systems. With the IP150+, connecting to a system is possible with the Insite GOLD application, PC software for programming, upgrade and monitoring, as well as reporting to the central station by connecting to Paradox receivers.

Before You Begin (Static Mode Only)

Make sure you have the following in order to configure your IP150+ Internet Module:

- Router
- 4-pin serial cable (included)
- CAT5 Ethernet cable (maximum 90m (295 ft.), not included)
- Insite Gold app
- Paradox IP Exploring Tools Software (required for remote access)
- Connect IP150+ to the serial port on your panel and Ethernet port of your router

Figure 1 - IP Communication Overview

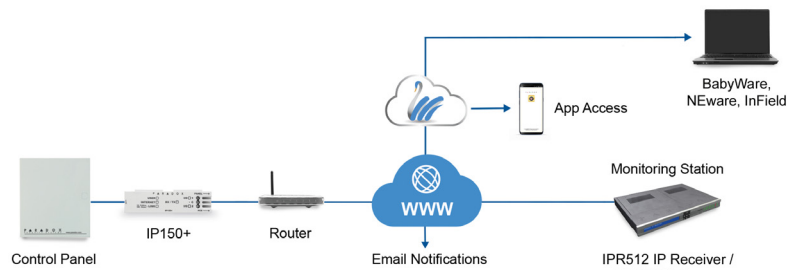

Connecting and Installing the IP150+

Figure 2 - IP150+ Overview

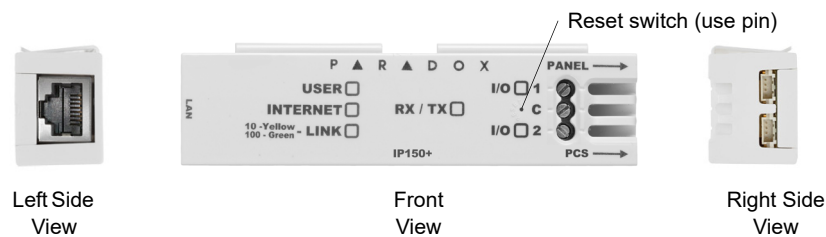

Installation

Figure 3 - Metal and Plastic Box Installation

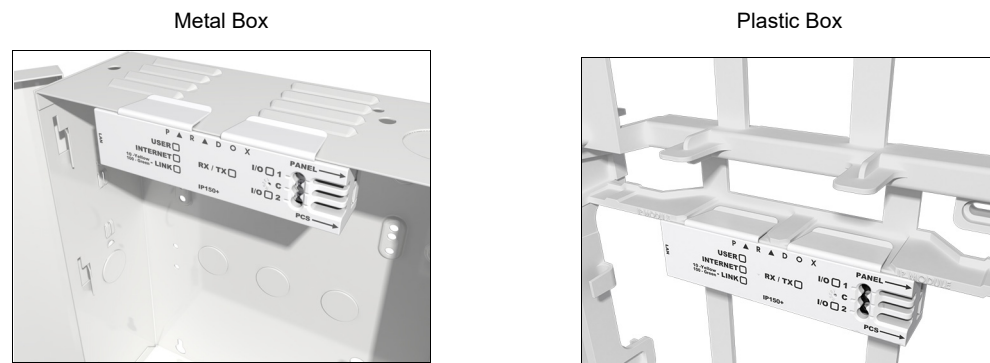

To connect and install the IP150+:

- 1) Connect the 4-pin serial cable between the panel's serial connector and the IP150+'s panel connector.
- 2) Connect the Ethernet cable between the router and the IP150+'s network connector.
- 3) The on-board LEDs will illuminate to indicate the IP150+'s status.
- 4) Clip the IP150+ to the top of the metal box or plastic box, as shown in Figure 3.

LED Indicators

LED	Description	
User	Green - On when a user is connected via Insite Gold/BabyWare/InField.	
Internet	Solid green	Internet present and SWAN connected
	Flashing - Internet present	Trying to connect to the SWAN server
	Off	No internet connection
Link	Solid Yellow = connected @ 10Mbps	
	Solid Green = connected @ 100Mbps	
	LED will flash according to data traffic	
	Flashing Yellow/Green = No IP address / DHCP fail (check router)	
RX/TX	On when connected to panel	
	Flashes when data is transmitted or received through/from panel	
	Off when no connection to panel	
I/O 1	On when activated	
I/O 2	On when activated	

Reset IP150+ to Default Settings

To reset the IP150+ module to its default settings, ensure that the module is turned on and then insert a pin/straightened paper clip (or similar) into the pinhole located between the two I/O LEDs. Press down gently until you feel some resistance; hold it down for approximately five seconds. When the I/O and RX/TX LEDs start flashing, release it and then press it again (figure 2). The I/O and RX/TX LEDs will remain lit during the reset.

Reset IP150+ to Default Firmware Version

To reset the IP150+ module to its default firmware version, unplug the power cable from the panel and insert a pin/straightened paper clip (or similar object) into the pinhole located between the two I/O LEDs. Press down gently until you feel some resistance; plug in the power cable while holding the pin down for approximately five seconds and release it when the I/O 2 LED starts flashing (figure 2). The I/O LED will turn solid and start blinking (resetting to the backup version). Once complete, the IP150+ will reboot automatically to the default firmware version.

IP Reporting

When using IP reporting, the IP150+ has the ability to poll the monitoring station. To enable IP reporting, the IP150+ must first be registered to the monitoring station's IP Receiver (IPR512) or to the IPRS-7 software. Telephone reporting can be used in conjunction with, or as a backup to IP reporting. Before registering the IP150+, the following information must be obtained from the monitoring station:

- Account number(s) - One account number for each partition used. IP/GPRS reporting uses a different set of account numbers than those used for dialer reporting.
- IP address(es) - (12-digit number e.g., for 195.4.8.250 you must enter 195.004.008.250). The IP address(es) indicate(s) which of the monitoring station's IP Receivers will be used for IP reporting.
- IP port(s) (5-digit number; for 4-digit numbers, enter 0 before the first digit). The IP port refers to the port used by the monitoring station's IP Receiver.
- Receiver password(s) (up to 32-digits). The receiver password is used to encrypt the IP150+ registration process.
- Security profile(s) (2-digit number). The security profile indicates how frequently the monitoring station is polled by the IP150+. Security profile numbers and polling frequency are defined by the monitoring station.

Setting Up IP Reporting

- 1) Ensure the panel's report code format is set to Ademco Contact ID:
MG/SP: section [810]
EVO: section [3070]
- 2) Enter the IP reporting account numbers (one for each partition):
MG/SP: section [918] / [919]
EVO: section [2976] to [2983]

Please make sure that reporting codes are programmed in the panel, refer to the corresponding Programming Guide for more details.

In the General IP Options section, set up IP line monitoring options and dialer options, and ensure IP reporting is enabled (refer to the following tables).

MG/SP: section [806]

IP Line Monitoring Options			
[5]	[6]		
Off	Off	Disabled	
Off	On	When disarmed: Trouble only When armed: Trouble only	
On	Off	When disarmed: Trouble only When armed: Audible alarm	
On	On	Silent alarm becomes audible alarm	
		OFF	ON
[7]	Use dialer reporting (telephone)	<input type="checkbox"/> As backup for IP/GPRS reporting	<input type="checkbox"/> In addition to IP reporting
[8]	IP/GPRS reporting	<input type="checkbox"/> Disabled	<input type="checkbox"/> Enabled

EVO: section [2975]

IP Line Monitoring Options			
[5]	[6]		
Off	Off	Disabled	
Off	On	When disarmed: Trouble only When armed: Audible alarm	
On	Off	When disarmed: Trouble only (default) When armed: Trouble only	
On	On	Silent alarm becomes audible alarm	
		OFF	ON
[7]	Use dialer reporting (telephone)	<input type="checkbox"/> As backup for IP/GPRS reporting	<input type="checkbox"/> In addition to IP reporting
[8]	IP/GPRS reporting	<input type="checkbox"/> Disabled	<input type="checkbox"/> Enabled

- 4) Enter the monitoring station's IP address(es), IP port(s), receiver password(s), and security profile(s) (information must be obtained from the monitoring station).

MG/SP Sections

IP Receiver	#1	#2	Backup
IP Address1	[929]	[936]	[943]
IP Port1	[930]	[937]	[944]
IP Address2	[931]	[938]	[945]
IP Port2	[932]	[939]	[946]
IP Password	[933]	[940]	[947]
IP Profile	[934]	[941]	[948]

EVO Sections

IP Receiver	#1	#2	#3	#4
IP Address1	[2984]	[2986]	[2988]	[2990]
IP Port1				
IP Address2				
IP Port2				
IP Password				
IP Profile				

- 5) Register the IP150+ module with the monitoring station. To register, enter the sections below and press [ARM]. The registration status is displayed as well as any registration errors.

MG/SP Registration

IP Receiver #	#1	#2	Backup
Register/Status	[935]	[942]	[949]

EVO Registration

IP Receiver #	#1	#2	#3	#4
Register/Status	[2985]	[2987]	[2989]	[2991]

NOTES:

An IP150+ used with an MG/SP system will always poll using the partition 1 IP account number. When using an EVO system, the partition 1 IP account is used by default, but can be defined in section [3020]. All reported system events will originate from the partition selected in this section.

Remote Access (Static Mode Only)

In order to configure your system for remote access you will need IP Exploring Tools, a web browser and access to your router. The following steps will guide you in setting up remote access.

Step 1: Setting up the Router

This step allows you to set up the router so that the IP150+ module can function properly.

- 1) Ensure the router is connected properly as indicated in the router's instructions.
- 2) Access your router's configuration page. Refer to your router's manual for the exact procedure. In most cases, this is done by entering the router's static IP address in the address bar of your Web browser. For this instance, we will use 192.168.1.1 as an example for the router's IP address that may be indicated in the router's instructions or on a sticker on the router. Enter the monitoring station's IP.

- In the router's configuration page, check the DHCP settings (screen shot below may differ depending on type of router used).

Figure 4 - DHCP Settings

Use Router as DHCP Server

Starting IP Address: 192 . 168 . 1 . 5

Ending IP Address: 192 . 168 . 1 . 100

If DHCP is enabled, verify that the IP address range leaves at least one IP address available outside of the range. The range shown in the above example would leave addresses 2 to 4 and 101 to 254 available (all the numbers in an IP address are between 1 and 254). Record one of the addresses outside the DHCP range as the one you will use for the IP150+. If DHCP is disabled, the IP150+ will use a random IP address. It is possible to change that address if needed using the Paradox IP Exploring Tools software.

- In the router's configuration page, go to the Port Range Forwarding section (also known as "port mapping" or "port redirection"). Add a service/item, set the Port to 80 and enter the static IP address selected in the previous step for the IP module. If port 80 is already used, you can use another one, such as 81 or 82 but you will have to modify the IP150+'s settings in step 2. Some Internet Service Providers block port 80, therefore the IP150+ may function locally using port 80 but not over the Internet. If this is the case, change the port to another number. Repeat this step for port 10 000 (screenshot below may differ depending on type of router used). Also, repeat this step for port 443 if using a secure connection (https).

Figure 5 - Port Range Forwarding

Service Name: Internet Module

Service Type: TCP/UDP

Starting Port: 80 (1~65534)

Ending Port: 80 (1~65534)

Server IP Address: 192 . 168 . 1 . 101

Step 2: Configuring the IP150+

- Using a computer connected to the same network as the IP150+, open the Paradox IP Exploring Tools.
- Click **Find It**. Your IP150+ appears in the list.

Figure 6 - IP Exploring Tools

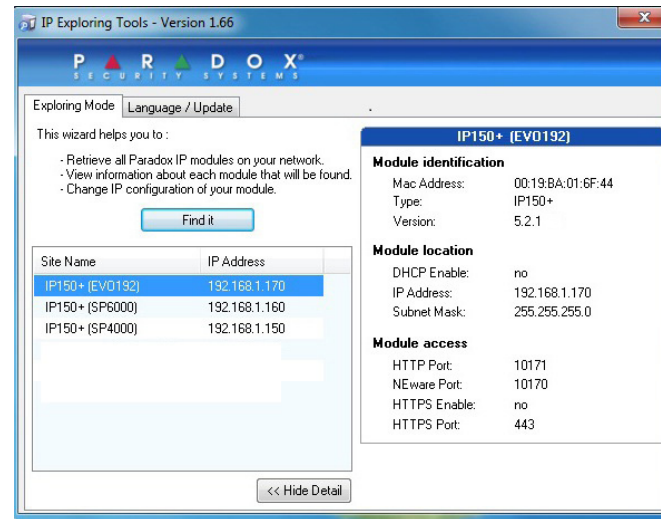

- Right-click your IP150+ and select **Module setup**, refer to screen shot below. Enter the static IP address you recorded in Step 1.3 or modify the address so that it corresponds to the one you have selected for the IP150+. Enter the IP150+'s password (default: paradox) and click **OK**. If it indicates that the IP address is already used, change it to another and modify it in the Port Forwarding of the router (Step 1.4) and go back to Step 2.1.
- Set any additional information such as port, subnet mask, etc. To find this information, click **Start > Programs > Accessories > Command Prompt**. Enter command: IPCONFIG /ALL (with space after IPCONFIG).

NOTE: For increased communication security, please change the default PC password and Panel ID in the control panel. Also, note that the IP150+ supports SMTP/ESMTP/SSL/TLS protocols.

Figure 7 - Module Setup

Module setup

Obtain an IP address automatically

IP address: 192 . 168 . 1 . 144

Subnet mask: 255 . 255 . 255 . 0

Site name: Your Paradox System

NEware port: 10000

HTTP port: 80

Enable HTTPS

HTTPS port: 443

Module password: []

OK Cancel

Step 3: Using a Web Browser to Access the System

Once the module is configured, it can be accessed either from the local network or through the internet using the alarm system's master code.

On-Site Access:

- Enter the IP address assigned to the IP150+ in the address bar of your Web browser. If you have used a port other than port 80, you must add [: port number] at the end. (For example, if the port used is 81, the IP address entered should look like this: http://192.168.1.250:81).
or
Use the Paradox IP Exploring Tools software, click **Refresh** and double-click on your **IP150+** in the list.
- Enter your alarm system's **User Code**.

WARNING: A pop-up warning you that the website's certificate is not secure may occur. This is acceptable, click to continue.

Inputs and Outputs Connections

To configure your I/O terminals please refer to the IP150+ Programming Guide. Refer to figures 8 and 9 for examples of input and output connections.

Figure 8 - Input Connection Example

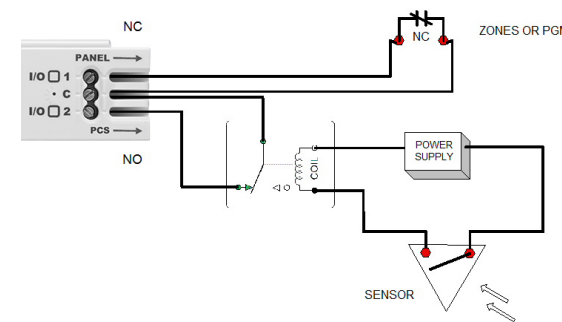
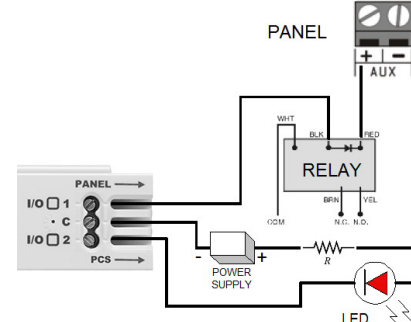

Figure 9 - Output Connection Example



Technical Specifications

The following table provides a listing of the technical specifications for the IP150+ Internet Module.

Specification	Description
Panel Compatibility	Any Digiplex EVO panel (V2.02 for IP reporting) Any Spectra SP series panel (V3.42 for IP reporting) Any MG5000 / MG5050 panel (V4.0 for IP reporting) MG5075 panel (V1.01)
Encryption	MD5 and RC4
Current Consumption	100mA
Input Voltage	13.8 Vdc, supplied by the panel serial port
Enclosure Dimensions	10.9cm x 2.7cm x 2.2cm (4.3in x 1.1in x 0.9in)
Approvals	CE, EN 50136-1, EN 50136-2 SP5, EN 50131-10 Grade 3, Class II

Warranty

For complete warranty information on this product, please refer to the Limited Warranty Statement found on the Web site www.paradox.com/Terms. or contact your local distributor. Specifications may change without prior notice.

Patents

US, Canadian and international patents may apply. Paradox is a trademark or registered trademarks of Paradox Security Systems (Bahamas) Ltd. © 2020 Paradox Security Systems (Bahamas) Ltd. All rights reserved. www.paradox.com

