

INSTALLATION – TOUCH-10 10” TouchControl Touch Screen RCT

ENCLOSURE: Steel IP30 RAL 9005
 DIMENSIONS: 290 x 205 x 85 mm



TRIM RING
 Fixing screws M2 (x2)

ENCLOSURE MOUNTING

This unit is designed to be flush mounted into stud walling. Cut out the aperture in the wall to 3mm larger than the size of the back box. Nominal 272x180, (Min 270x178, Max 274x182)

ENCLOSURE FIXING POINTS

4x fixing holes in rear of enclosure or 4x fixing slots in side walls
 Side wall slots allow adjustment for uneven walls.

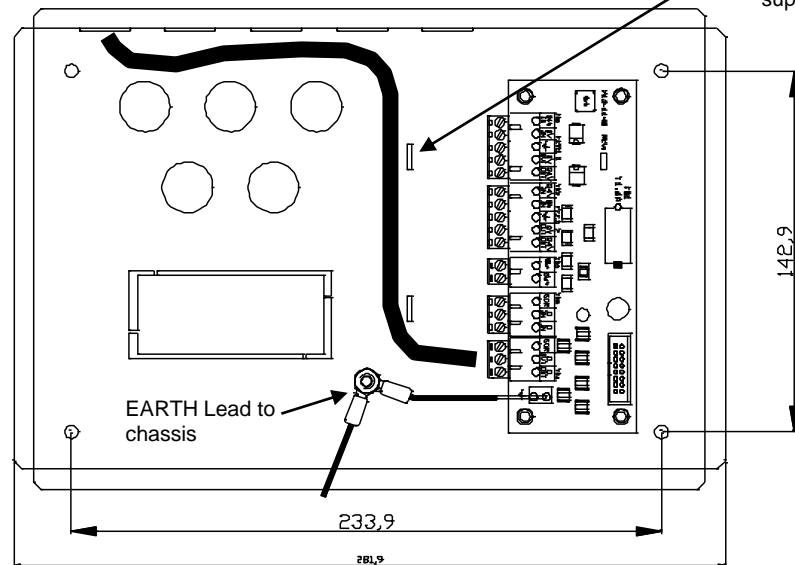
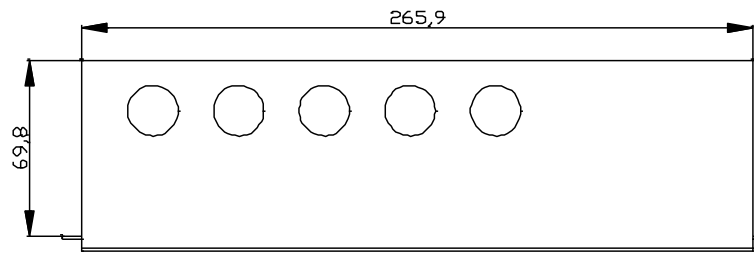
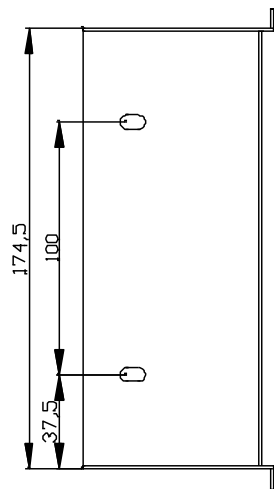

EARTH Lead to chassis

CABLE ROUTING
 Route cables from the knockouts as shown and tie to anchor points with the supplied cable ties.

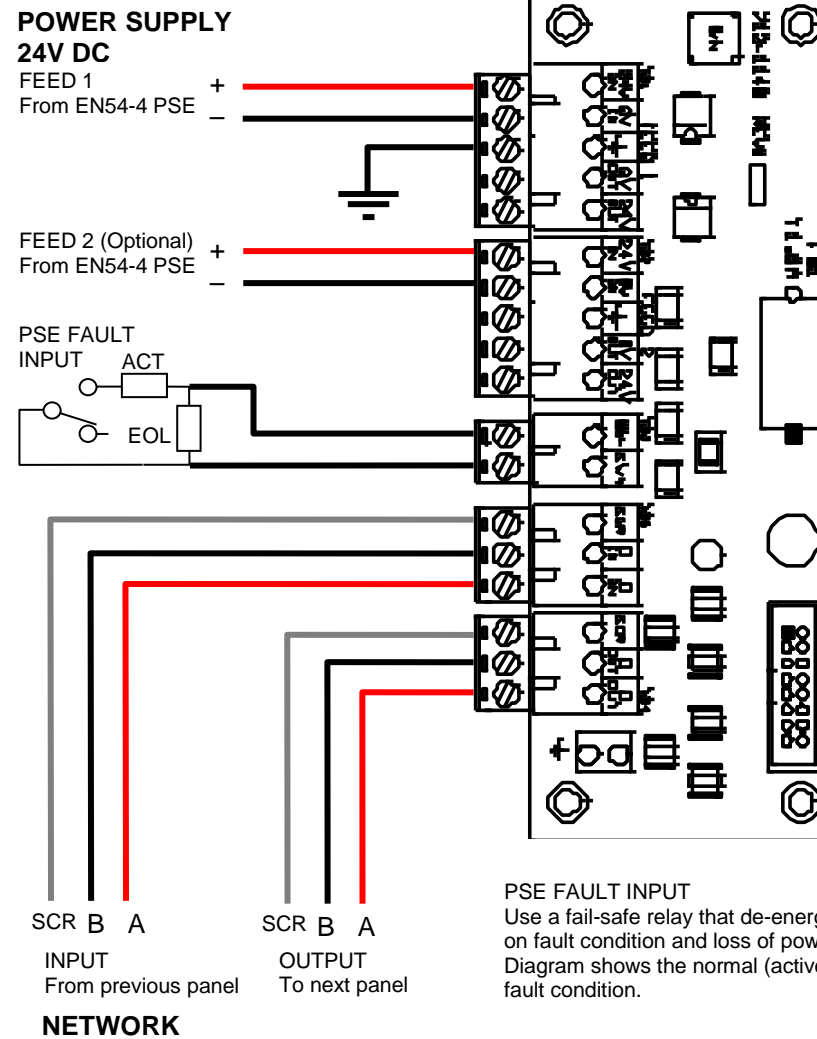

PSE FAULT INPUT
 Use a fail-safe relay that de-energises on fault condition and loss of power. Diagram shows the normal (active) no fault condition.

ENCLOSURE OPENING
 Unscrew the trim ring fixings screws so that the bottom of the trim ring can be pulled forward, slide up and remove. There is no need to fully remove the screws from the trim ring! The trim ring is hooked onto the upper flange and secured with the screws locating behind the lower flange

The touch screen module can be pulled forward by 30mm to gain access to USB sockets underneath.

To fully remove the chassis lift up the pin levers either side to disengage the internal catches and remove the chassis. Disconnect the earth lead from the tab on the chassis and the ribbon cable from the termination card.



ADVANCED ELECTRONICS LTD
 Moorland Way, Nelson Park, Cramlington
 Northumberland, United Kingdom, NE23 1WE

14

TOUCH-10, TOUCH-10/FT

Technical data:
 See document 680-217.

GLASS
 Take care when handling the unit. The glass touch screen is fragile.

EARTH
 The unit must be connected to earth for ESD protection.



Environment	Indoor, Dry
Supply Voltage	18-30V DC
Supply Current	300mA
FUSE – PCB	T250H1.6A
PSE Fault Monitoring	EOL 3300Ω, ACT 680Ω
Operating Temperature	-5°C to +40°C
Relative Humidity	95%
Wire Gauge (max.)	2.5mm ²
Knockouts (20mm)	5 Top, 5 Rear
Models	TOUCH-10, TOUCH-10/FT

For more information see document 680-217

	REV	02
	Drawing Name	Installation - TOUCH-10
DRAWN BY	DW	Drawing Number 683-TC10
CREATED	11/08/2014	